

# Scanner Installation Guide

## 1. Unpack Contents

Unpack your scanner package and check for major components.

- A. Scanner
- B. Hi-Speed USB 2.0 cable
- C. Power cord
- D. Software CD/DVD

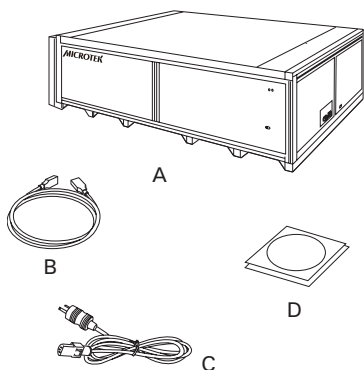

## 2. Install Software

**Important:** You must install software before connecting your scanner. Always close any open programs and turn off Antivirus utilities before installing software.

- A. Place the Microtek Software CD/DVD into a drive, and follow the on-screen instructions to install the scanner driver and software.

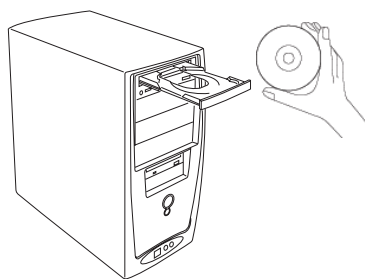

*NOTE: If the Microtek Software Installer screen does not come up automatically, double-click the following in succession: "My Computer"; the CD/DVD-ROM icon; then Setup.exe to start the installer program.*

- B. Restart your computer at the end of all software installation.

## 4. Connect Scanner

### To the power cord

- A. Connect one end of the power cord to the right side of the scanner and plug the other end into a power source.
- B. Press the power button to turn the scanner on. When the scanner is turned on, the power button light (the green power light) is on as well.

### To the Hi-Speed USB cable

- C. Connect one end of the USB cable to your computer and connect the other end to the scanner.

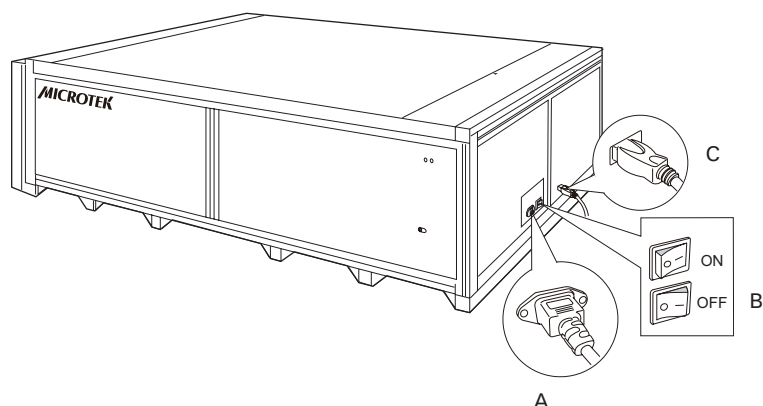

## Launch Scanning Software

After the software and scanner have been successfully installed and connected, double-click the scanning software icon (ScanWizard Graph, ScanWizard DTG, or ScanWizard Cubi) on the desktop to launch the software that you purchased and installed.

Refer to the User's Manual in the Microtek Software CD/DVD toward how to scan materials and how to use software.

## 3. Unlock Scanner

- A. Locate two locking screws at the right corner of the front panel of the scanner and at the left corner of the back panel of the scanner.
- B. Using a flat-head screwdriver, pass through a round circle at the outer shell of the scanner and insert a hollow side of the locking screw: 1) push to the end with force, and 2) turn the locking screw counterclockwise 90 degrees to the unlock position.

When successfully unlocked, the screw will push out a little, protruding slightly from the front of the scanner.

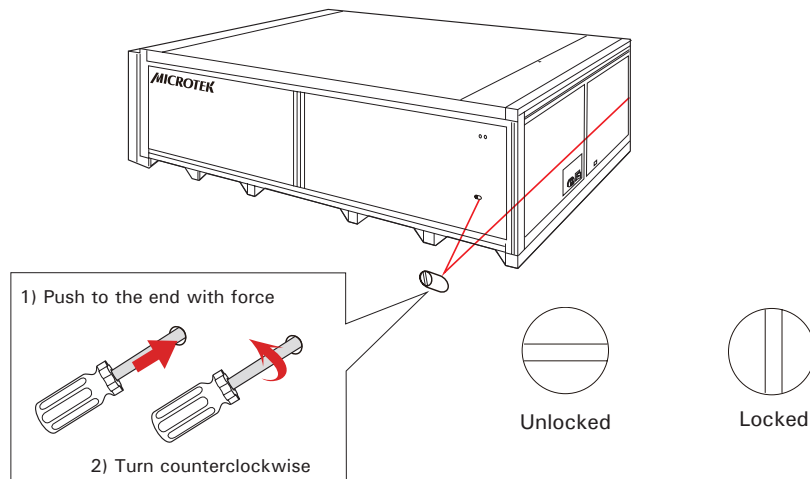

*NOTE: To lock the scanner (for shipping or other reasons), refer to the User's Manual in the Microtek Software CD/DVD.*

## Position Materials

Place the material to be scanned face down on the scan bed (scanner glass surface), towards the right of the scanner. Center the top of the original along the ruler on the scanner.

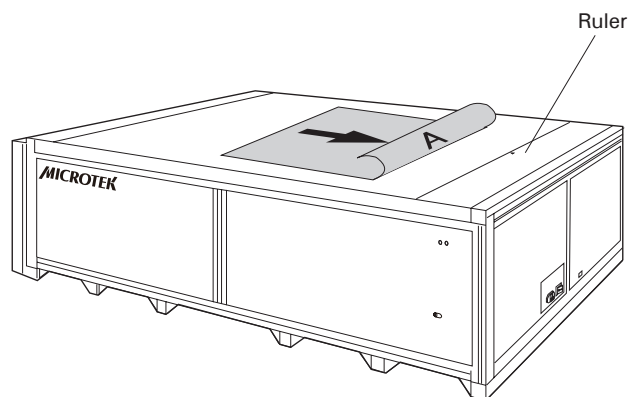

## Do You Need Assistance?

### Missing Items

If your package is missing items or you have questions toward the installation of the scanner, please call Microtek Customer Service Department.

### Drivers & Software Upgrades

After you finish the installation of software, if you found that the installed drivers and software cannot run your product or your computer system properly later, please go to the Microtek Download Service site at [www.microtek.com/service.php](http://www.microtek.com/service.php) to download and install any updates you may require.

For additional information about Microtek products, please visit our website at [www.microtek.com](http://www.microtek.com).