

Supplement

ArtixScan F2 features, scenarios, and information



Getting to Know Your ArtixScan F2

The ArtixScan F2 is a combined flatbed and film scanner for 35mm, 6-cm, and 4"x5" film formats that also offers additional functionality to scan reflective art or prints as large as 8.5" x 14". It features 4800 x 9600 dpi optical resolution, 4.2 maximum optical density, and a Hi-Speed USB interface for the fast and plug-and-play connectivity ability. The ArtixScan F2 is equipped with Microtek's patented Emulsion Direct Imaging Technology (E.D.I.T.) for delivering distortion-free images in transparency scanning. The scanner also features ColoRescue™ one-touch color restoration for both photos and film.

Contents

Getting to Know Your ArtixScan F2	1	C. Scanning Negative Film	21
Features of the ArtixScan F2	2	D. Scanning Photos (or Film) Applied with Auto Focus	24
Taking a Closer Look.....	3	For Mac Users Using ScanPotter.....	27
Unlocking the Scanner	4	A. Scanning Photos	27
Positioning Your Originals.....	5	B. Scanning Film.....	29
Using the Glass Holder	7	Using the Microtek Scanner ICC Profiler (MSP).....	31
Using the Other Film Holders.....	8	MSP and IT8 Calibration Data Installation.....	31
A. Using the 35mm Slide Holder.....	9	Calibration Target.....	31
B. Using the 35mm Filmstrip Holder	10	Positioning the Target	32
C. Using the 6 x 22-cm (120) Film Holder.....	11	Calibration Setup	33
D. Using the 4" x 5" Film Holder.....	12	Calibration and Profiling	34
Scanning Scenarios.....	13	Loading a Profile.....	35
For PC Users Using ScanWizard Pro.....	14	Specifications / System Requirements	36
A. Scanning Photos.....	14	FCC Compliance Statement	37
B. Scanning Positive Film	18		

Features of the ArtixScan F2

The ArtixScan F2 comes with several important features, including the following:

- **Energy-saving LED light source:** Adopting LEDs as the light source, when the scanner is detected by the system, there are no requirements for any warm-up time before carrying out the scan, which boots your productivity and reduces energy costs amazingly. With its stable performance, the image quality will remain consistent even after used for a certain period of time.
- **Microtek's Emulsion Direct Imaging Technology (E.D.I.T.):** This is a patented “glassless” scanning system built into the lower bay of Microtek’s dual media scanners, allowing the scanner CCD to directly read the emulsion side of the film during scanning without any interfering pane of glass. This effectively eliminates problems associated with normal glass transparency scanning like Newton Rings, resulting in distortion-free images.
- **Auto Focus:** An image improvement feature introduced to Microtek flatbeds, Auto Focus allows the scanner to change the focus position on images through the movement of the CCD, resulting in better image quality for a chosen area of the scan. Auto Focus is activated by default when the scanner is on but can be switched off manually before the final scan is carried out. The results of Auto Focus can be best seen when used with uneven, creased photos and film.
- **Microtek's ColoRescue™ system:** With ColoRescue, the ArtixScan F2 restores faded colors in photos and film, bringing hues back to their original luster and brilliance for more vibrant images. ColoRescue's one-click, automatic color recovery process is simple and straightforward, involving no learning curve or hassle.
- **Microtek ScanWizard™ Pro scanning software (PC):** This is an advanced scanner controller program that provides many powerful, professional-level features for scanning. ScanWizard Pro includes the Microtek Scanner ICC Profiler (MSP) program, which allows users to calibrate the scanner and generate the appropriate ICC color profile to ensure color consistency and accuracy during the scanning process. ScanWizard Pro also features two color spaces, allowing users to work in the Native CMYK / RGB mode, as well as in the intuitive LCH (Lightness, Chroma, Hue) mode.
- **ScanPotter scanning software (Mac):** ScanPotter is a professional and exclusive scanner software designed for the Mac system which is still under development. It may not come with your scanner package. Microtek will provide it to you as soon as possible when it is ready.

Taking a Closer Look

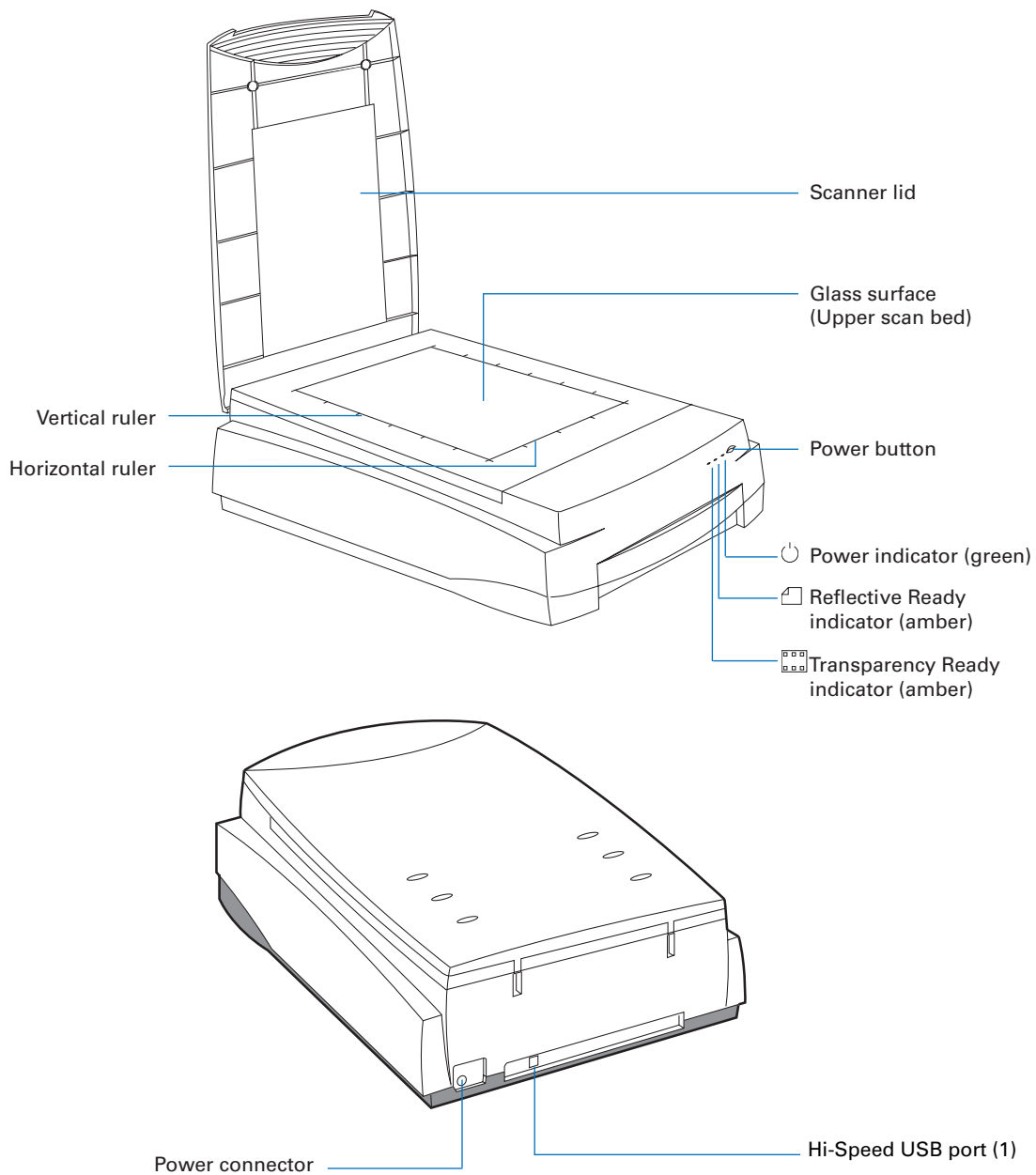

Unlocking the Scanner

Before you can operate the scanner, you will need to unlock the scanner. To unlock the scanner, follow the steps below:

1. Remove the yellow “Step 3” sticker from your scanner.
2. Look for the unlocking screw at the bottom of the scanner.
3. Using a screwdriver, push and turn the locking screw counterclockwise to the unlock position.

When successfully unlocked, the screw will push out a little, protruding slightly from the bottom of the scanner.

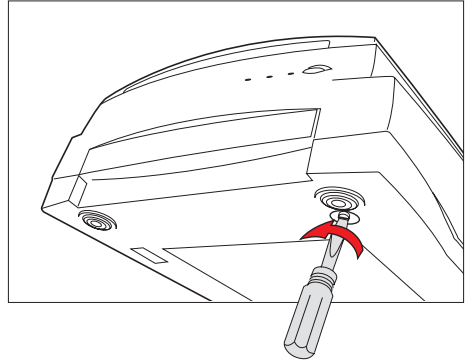

Shipping the Scanner

If you have to transport the scanner, you will need to lock the scanner back. Follow the steps below:

1. Turn off the scanner if your scanner is on.
2. Turn the scanner back on. The scanner's carriage will move to the standby position in 5 minutes.
3. When the indicators on the front of your scanner stop blinking, use a screwdriver, and then push and turn the locking screw clockwise to the locked position.

When the screw has been tightened, this indicates that your scanner is locked.

4. Turn off your scanner. The scanner is now ready for transport.

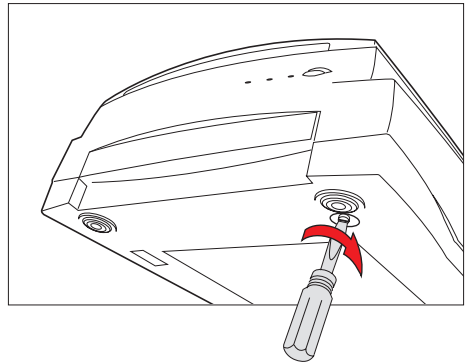

Positioning Your Originals

Positioning Reflective Originals

This procedure applies when you use the upper scan bed of the ArtixScan F2 to scan reflective materials such as photos and prints.

1. Open the scanner lid.
2. Place the original to be scanned face down on the scanner glass bed, towards the front of the scanner. Center the top of the original along the horizontal ruler on the scanner.

Note: To scan a book or thick materials/documents, lift the scanner lid out of its hinge sockets high enough to create room between the originals and the lid.

3. Lower the scanner lid.

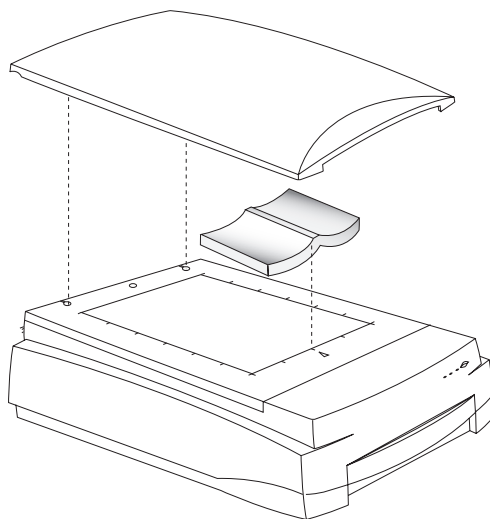
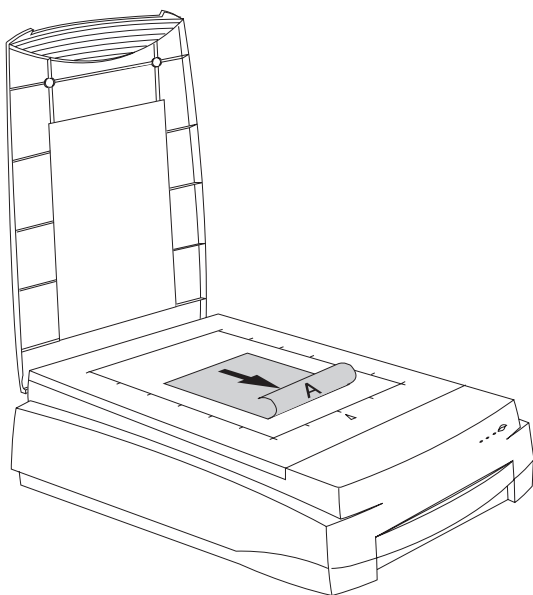

Positioning Transparent Film

This procedure applies when you use the lower scan bed of the ArtixScan F2.

There are two ways to scan transparent film:

- A. By using the Glass Holder to scan non-standard-size transparent film.

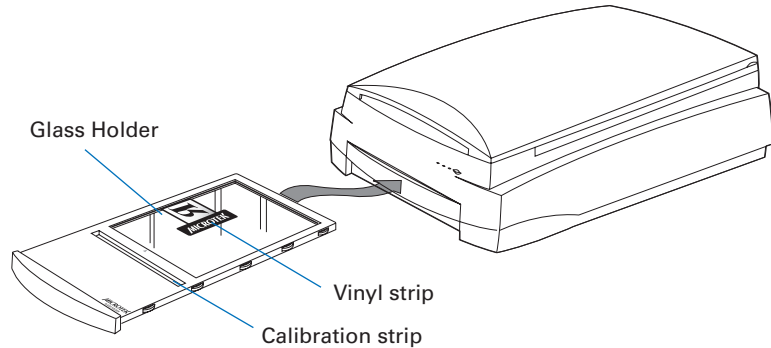

Important:

When using the Main Holder or the Glass Holder, make sure you use the correct side up when inserting the holders into the scanner. The correct side up is the side showing the holder labels facing up.

Make sure that the calibration strip on the holders are kept clear and free of obstruction at all times; no material should ever be placed on this area. Also, make sure the calibration strip faces the front of the scanner when you insert the holders into the lower compartment of the ArtixScan F2.

- B. By using the Main Holder, which is used together with individual film holders to scan standard-size transparent film, such as 35mm slides, 35mm filmstrips, 6 x 4.5-cm, 6 x 6-cm, 6 x 7-cm, 6 x 9-cm, 6 x 17-cm, 6 x 22-cm, or 4" x 5" films.

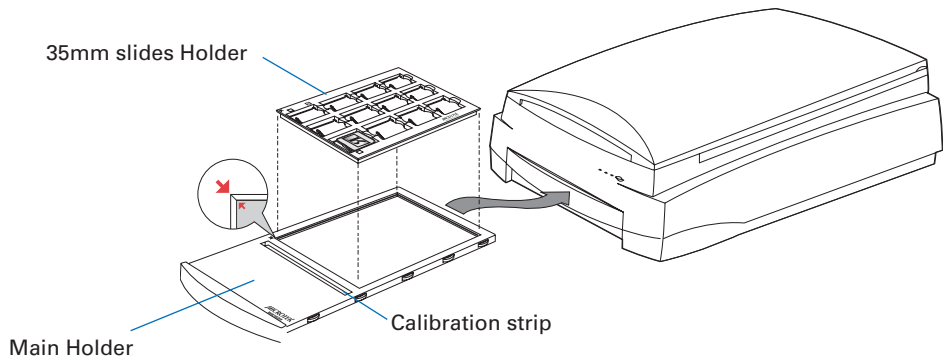

Using the Glass Holder

The Glass Holder is used to scan non-standard-size transparencies.

1. Place the film face down on top of the glass surface of the holder.

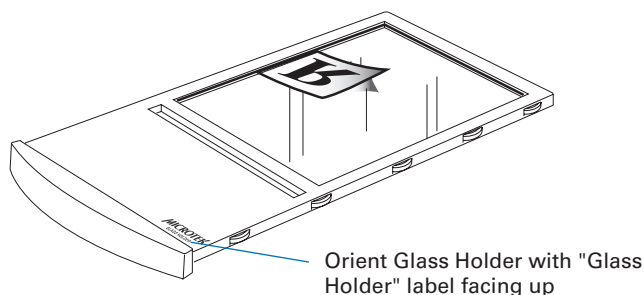

2. Secure the transparency to the glass by using the vinyl strips provided with your scanner.

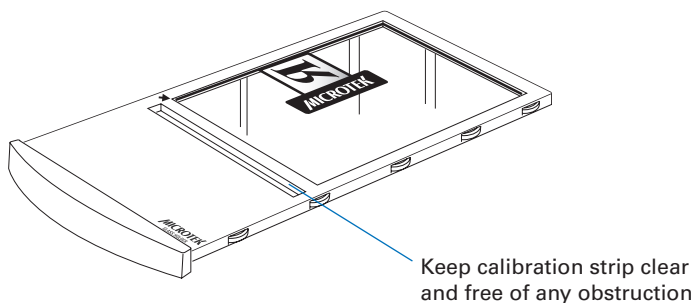

3. Insert the holder all the way into the transparency bay (the drawer or lower compartment) of the scanner.

Note: The Glass Holder requires regular cleaning. To clean, use mild glass cleaning solution, and wipe the glass plate gently with lint-free, lens-cleaning cloth to prevent leaving fiber residue.

Using the Other Film Holders

The other Film Holders are used together with the Main Holder to scan standard-size film. For instance, use the 4" x 5" Film Holder to scan 4" x 5" film, or use the 35mm Filmstrip Holder to scan 35mm filmstrips. The use of the individual film holders is explained in the succeeding pages of the manual.

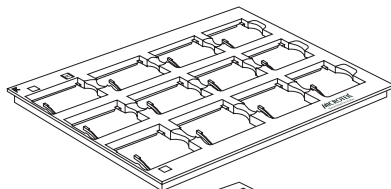

35mm Slide Holder

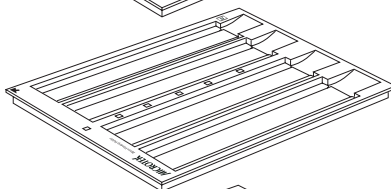

35mm Filmstrip Holder

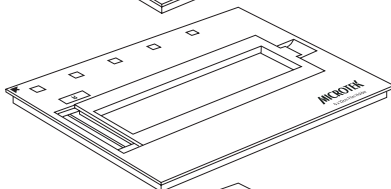

6 x 22-cm (120) Film Holder

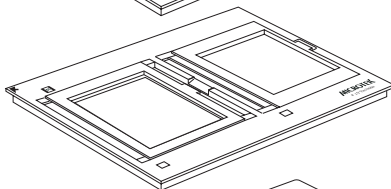

4" x 5" Film Holder

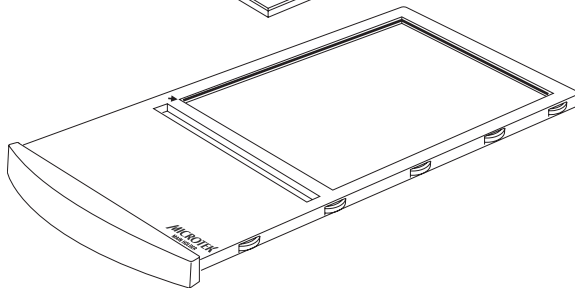

Main Holder

A. Using the 35mm Slide Holder

The 35mm Slide Holder can hold a maximum of 12 mounted slides at a time.

1. Place the individual 35mm slide to be scanned into the 35mm Slide Holder, as indicated in the graphic below. The shiny base of the 35mm slide should be facing down.

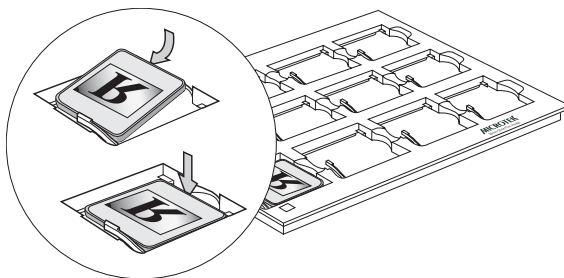

2. Put the 35mm Slider Holder into the Main Holder.

Make sure that the red arrow marks on both the 35mm Slide Holder and the Main Holder are pointing to each other when the holders are put together

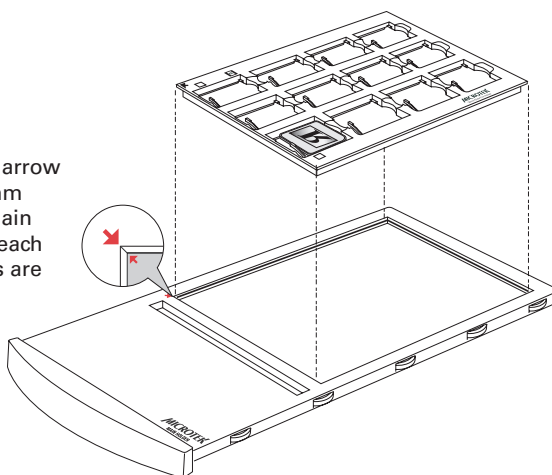

3. Insert the whole assembly into the transparency bay (the drawer or lower compartment) of the scanner.

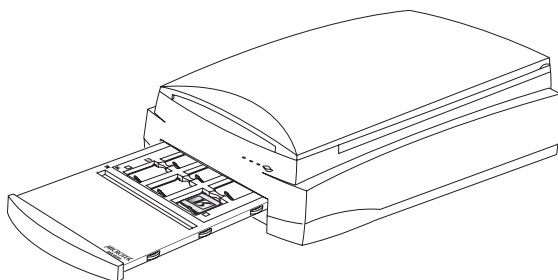

B. Using the 35mm Filmstrip Holder

The 35mm Filmstrip Holder can hold 4 strips of film that each consists of six frames. A total of four 35mm Filmstrip Holders is included in your scanner package.

1. Place the 35mm filmstrip to be scanned into the 35mm Filmstrip Holder, as indicated in the graphic below. The shiny base of the 35mm filmstrip should be facing down.

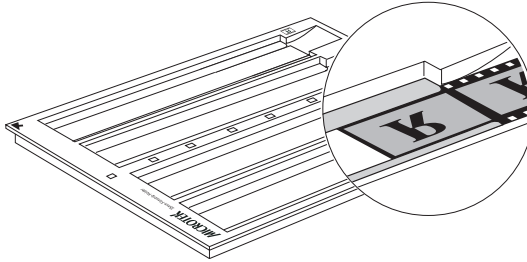

2. Put the 35mm Filmstrip Holder into the Main Holder.

Make sure that the red arrow marks on both the 35mm Filmstrip Holder and the Main Holder are pointing to each other when the holders are put together

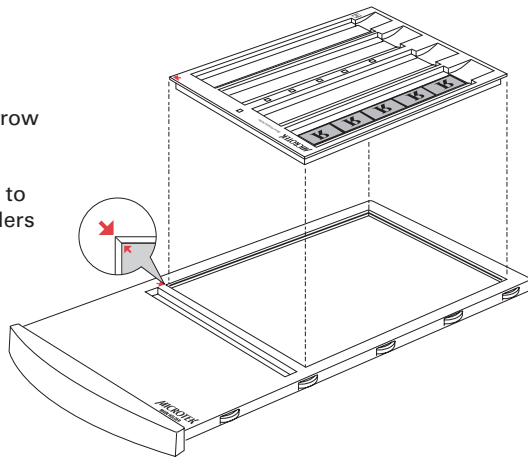

3. Insert the whole assembly into the transparency bay of the scanner.

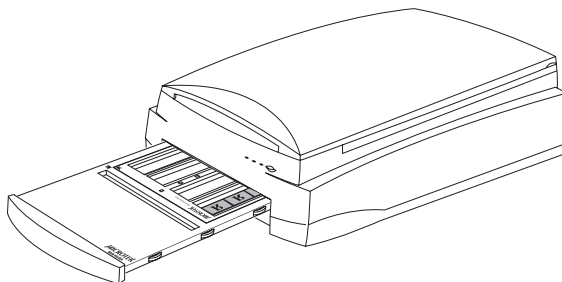

C. Using the 6 x 22-cm (120) Film Holder

The 6 x 22-cm (120) Film Holder can hold up to four pieces of 6 x 4.5-cm film, 2 pieces of 6 x 9-cm film, or a single piece of 6 x 17-cm film.

1. Place the film to be scanned into the 6 x 22-cm (120) Film Holder, as indicated in the graphic below. The shiny base of the film should be facing down.

a) Push on the side to open the lid.

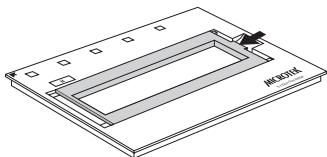

b) Place the film face down into the holder.

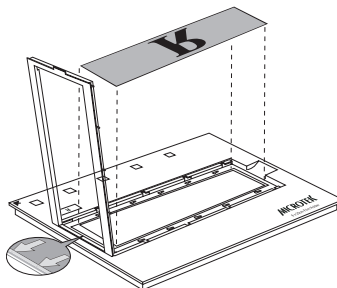

c) Pull down the side to close the lid.

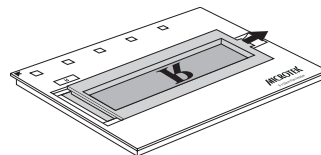

2. Put the 6 x 22-cm (120) Film Holder into the Main Holder.

Make sure that the red arrow marks on both the 6 x 22-cm Film Holder and the Main Holder are pointing to each other when the holders are put together

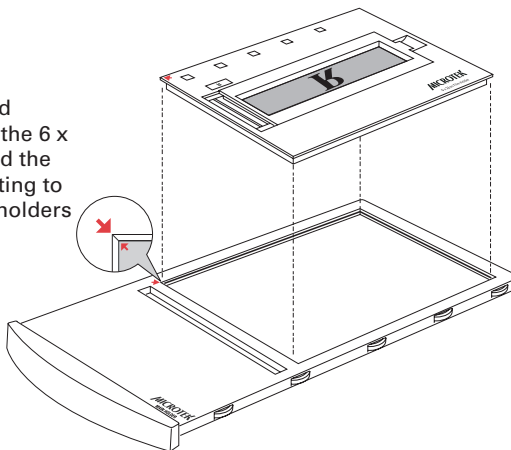

3. Insert the whole assembly into the transparency bay of the scanner.

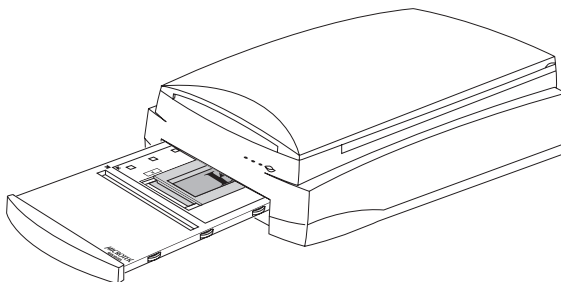

D. Using the 4" x 5" Film Holder

The 4" x 5" Film Holder can hold two pieces of 4" x 5" film at a time.

1. Place the 4" x 5" film to be scanned inside the 4" x 5" Film Holder, as indicated in the graphic below. The shiny base of the 4" x 5" film should be facing down.

- a) Push on the side to open the lid.

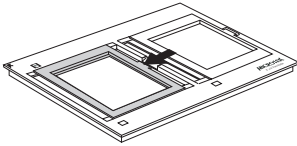

- b) Place the film face down into the holder.

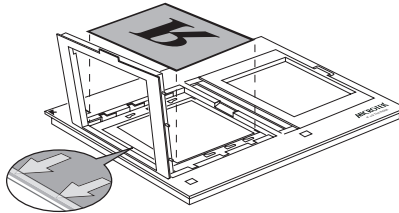

- c) Pull down the side to close the lid.

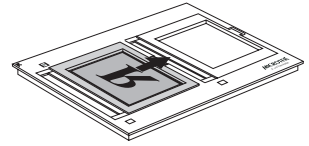

2. Put the 4" x 5" Film Holder into the Main Holder.

Make sure that the red arrow marks on both the 4" x 5" Film Holder and the Main Holder are pointing to each other when the holders are put together

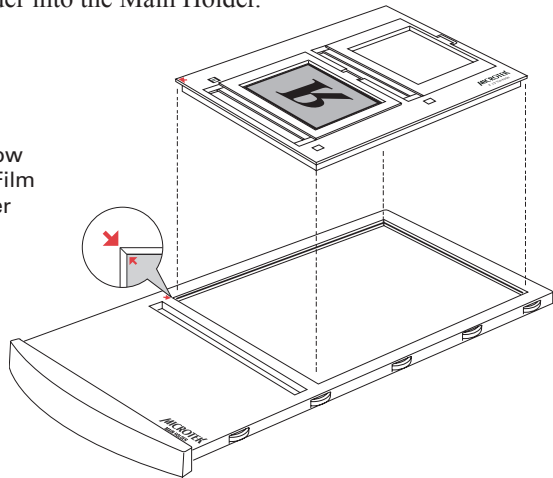

3. Insert the whole assembly into the transparency bay of the scanner.

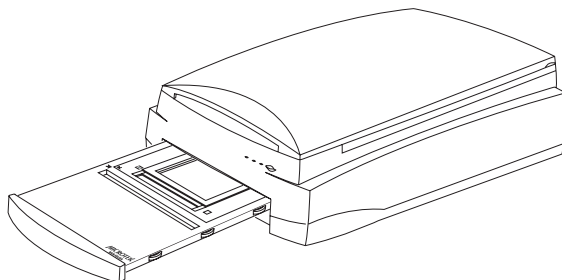

Scanning Scenarios

The following pages provide various scenarios for scanning with the ArtixScan F2, including the following:

For PC Users Using ScanWizard Pro,

- Scanning photos: This scenario can also be your first scan in order to familiarize yourself with scanning basics.
- Scanning positive film: This scenario details the steps for scanning positive film, such as 35mm mounted slides.
- Scanning negative film: This scenario details the steps for scanning negative film, such as 35mm filmstrips, 6 x 4.5-cm, 6 x 6-cm, 6 x 7-cm, 6 x 9-cm, 6 x 17-cm film, and 4" x 5" film.
- Scanning materials applied with the Auto Focus function: This scenario details the steps for applying the Auto Focus function to a selected area of the image to be scanned, in order to improve that area of the image.

For Mac Users Using ScanPotter,

- Scanning photos: This scenario details the steps for scanning photos.
- Scanning film: This scenario details the steps for scanning film.

For PC Users Using ScanWizard Pro

A. Scanning Photos

1. Raise the scanner lid, and place the photo to be scanned face down on the scanner glass bed, towards the front of the scanner. Center the top of the photo along the horizontal ruler on the scanner.
2. Launch ScanWizard Pro either as a stand-alone by clicking on the program icon, or by using the File-Import or File-Acquire command from your image-editing program (such as Adobe Photoshop).
 - The first time you launch ScanWizard Pro, you will be prompted to perform color calibration for your scanner.

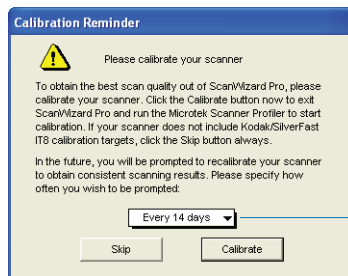
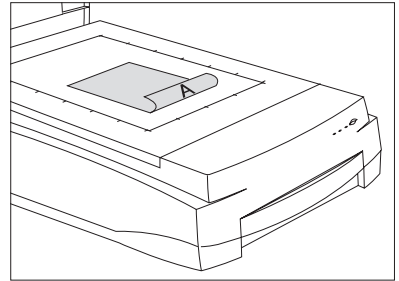

Allows you to specify how often you wish to be prompted to calibrate the scanner. The default setting is 14 days

- Click the **Skip** button to exit the “Calibration Reminder” window. Clicking the Skip button allows you to use the factory default ICC profile for your scanner.

***Note:** If your scanner does not include IT8 calibration targets, disregard the Calibration reminder window whenever it appears, and click the Skip button always.*

- Click the **Calibrate** button to run the Microtek Scanner ICC Profiler (MSP) program to perform color calibration and to customize the ICC profile for your scanner. After finishing with calibration, relaunch ScanWizard Pro.

***Note:** The MSP program should be installed before you perform color calibration for your scanner. For details on how to install the MSP program and how to use it to calibrate the scanner, refer to section of the manual titled “Using the Microtek Scanner ICC Profiler (MSP)”.*

- Next, you will be prompted to set up color matching for your scanner. If you are not sure about what to do, simply click the **OK** button to accept the settings. You can always change the settings at a later time.

For more information, see the *Color Matching Setup* section in the *ScanWizard Pro Reference Manual* in the Microtek Software CD/DVD.

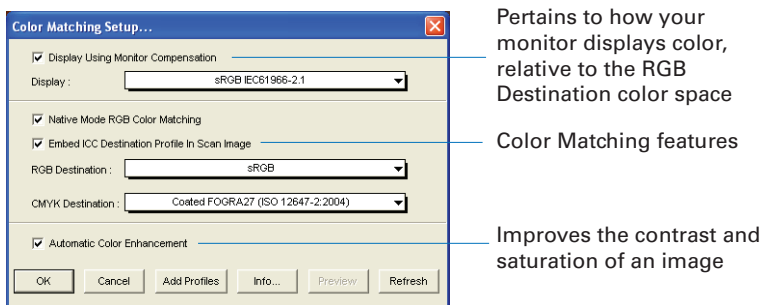

3. Go to the Preview window of ScanWizard Pro, and choose **Reflective** from the **Scan Material** menu.
4. Optional: If calibration has been performed, go to the Settings window in ScanWizard Pro. Choose the profile you have just created in the **Input Profile / Scanner Profile** menu.
5. Click the **Overview** button to perform a preliminary scan of the image, which will appear in the Preview window.
6. Select the **Scan Frame** tool from the Toolbar in the Preview window, and choose the area to be scanned by dragging a rectangle around it. You will see a flashing frame (marquee) around the selected area.
7. Click the **Prescan** button to display a detailed image area selected via the Scan Frame tool. A thumbnail of the image appears as well in the Scan Job Queue window.
8. Specify your scanning requirements in the Settings window.
 - a) Select a desired image type.
 - b) Select a desired resolution.
 - c) Adjust the scan frame settings if necessary.
9. Adjust image quality if necessary, using the Advanced Image Correction (AIC) tools.
10. If the colors in your photo are faded and needed restoring, check the “Automatic Color Restoration” box in the Settings window.

11. Click the **Scan** (or “Batch”) button in the Preview window to start scanning.

- If ScanWizard Pro was launched from an application program, the image is then delivered to your application, where the image can be saved, printed, or edited.
- If ScanWizard Pro was launched in stand-alone mode, you will be prompted to specify the file attributes for the scanned image after the Scan or Batch button is pressed, such as entering the file name, specifying a folder name of your own, etc. When you have completed the settings, press the Done/Save button, and the scanner will automatically scan and save your image based on your settings.

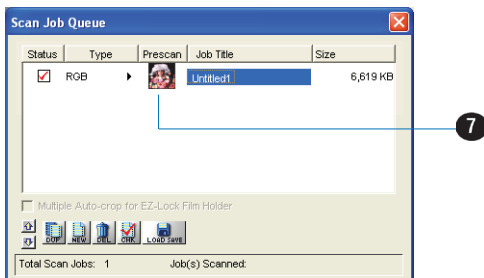
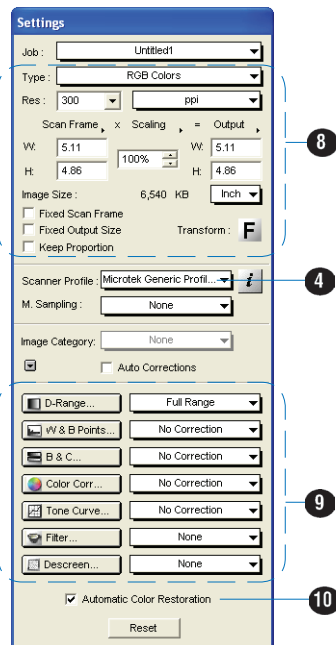
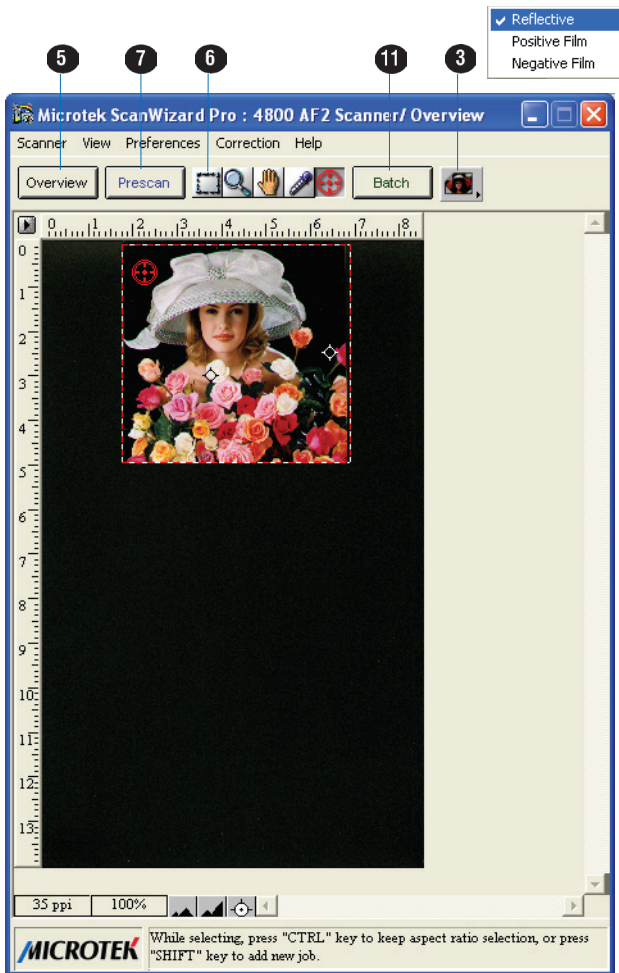

B. Scanning Positive Film

1. Insert the holder with the positive film into the transparency bay of the scanner. Make sure that nothing is on the scanner glass surface.
2. Launch ScanWizard Pro either as a stand-alone by clicking on the program icon, or by using the File-Import or File-Acquire command from your image-editing program (such as Adobe Photoshop).
3. Go to the Preview window and choose **Positive / Positive Film** from the **Scan Material** menu.

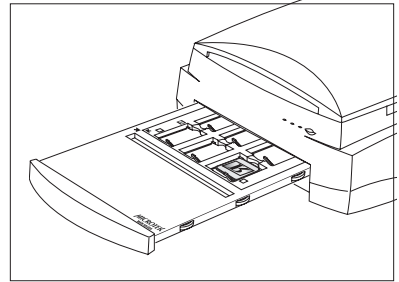

If this is your first time to scan transparent media, you will be prompted to perform color calibration for your scanner. A Calibration Reminder window appears.

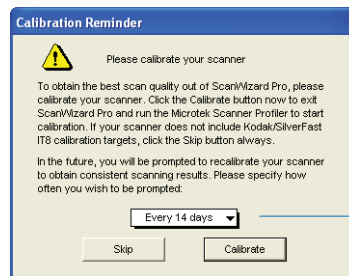

Allows you to specify how often you wish to be prompted to calibrate the scanner. The default setting is 14 days

- Click the **Skip** button to exit the “Calibration Reminder” window. Clicking the Skip button allows you to use the factory default ICC profile for your scanner.

***Note:** If your scanner does not include IT8 calibration targets, disregard the Calibration reminder window whenever it appears, and click the Skip button always.*

- Click the **Calibrate** button to run the Microtek Scanner ICC Profiler (MSP) program to perform color calibration and to customize the ICC profile for your scanner. After finishing with calibration, relaunch ScanWizard Pro.

***Note:** The MSP program should be installed before you perform color calibration for your scanner. For details on how to install the MSP program and how to use it to calibrate the scanner, refer to section of the manual titled “Using the Microtek Scanner ICC Profiler (MSP)”.*

4. Optional: If calibration has been performed, go to the Settings window in ScanWizard Pro. Choose the profile you have just created in the **Input Profile / Scanner Profile** menu.
5. Click the **Overview** button to perform a preliminary scan of your original.
6. Select the **Scan Frame** tool from the Toolbar in the Preview window, and choose the area to be scanned by dragging a rectangle around it. You will see a flashing frame (marquee) around the selected area.
7. Click the **Prescan** button to display a detailed image area selected via the Scan Frame tool. A thumbnail of the image appears as well in the Scan Job Queue window.
8. Specify your scanning requirements in the Settings window.
 - a) Select a desired image type.
 - b) Select a desired resolution.
 - c) Adjust the scan frame settings if necessary.
9. Adjust image quality if necessary, using the Advanced Image Correction (AIC) tools.
10. If the colors in your film are faded and need restoring, check the “Automatic Color Restoration” box in the Settings window.
11. Click the **Scan** (or “Batch”) button in the Preview window to start scanning.
 - If ScanWizard Pro was launched from an application program, the image is then delivered to your application, where the image can be saved, printed, or edited.
 - If ScanWizard Pro was launched in stand-alone mode, you will be prompted to specify the file attributes for the scanned image after the Scan or Batch button is pressed, such as entering the file name, specifying a folder name of your own, etc. When you have completed the settings, press the Done/Save button, and the scanner will automatically scan and save your image based on your settings.

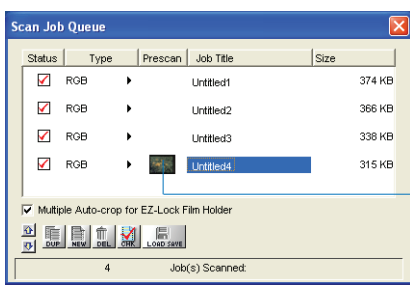
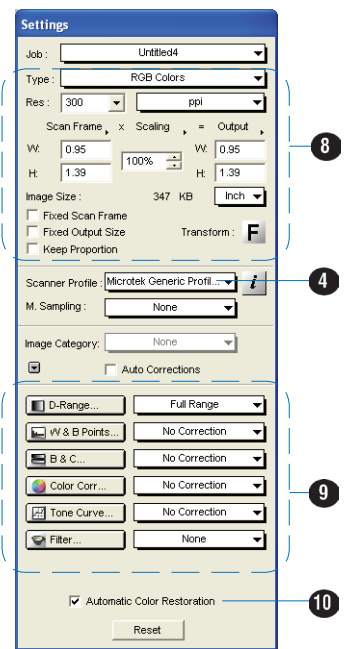
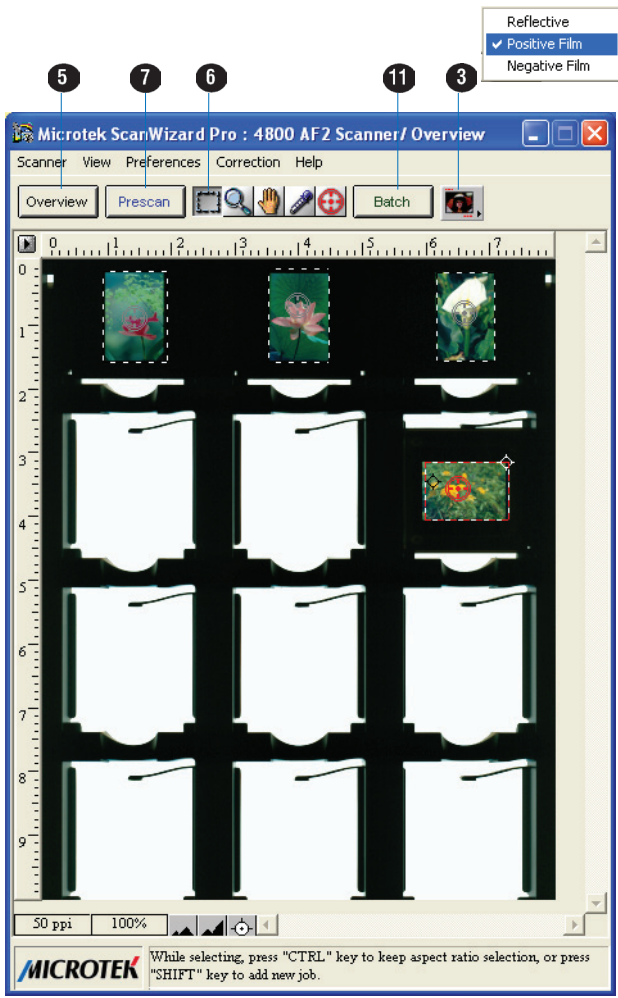

C. Scanning Negative Film

1. Insert the holder with the negative film into the transparency bay of the scanner.

Make sure that nothing is on the scanner glass surface.

2. Launch ScanWizard Pro either as a stand-alone by clicking on the program icon, or by using the File-Import or File-Acquire command from your image-editing program (such as Adobe Photoshop).
3. Go to the Preview window and choose **Negative / Negative Film** from the **Scan Material** menu.
4. Click the **Overview** button to perform a preliminary scan of your original.
5. Select the **Scan Frame** tool from the Toolbar in the Preview window, and choose the area to be scanned by dragging a rectangle around it. You will see a flashing frame (marquee) around the selected area.
6. Click the **Prescan** button to display a detailed image. A thumbnail of the image appears as well in the Scan Job Queue window.
7. In the Negative Scan Settings window, you can specify options related to your scanned negative film. Follow the steps below.

- a) In the *Negative Scan Settings* window, choose the Film Brand, Film Type, and ISO settings that match your film.
- b) The settings for the negative film you selected are applied to the prescan image, and the adjusted image is displayed in the Preview window.
- c) You can save the selected negative film settings into the Preset drop-down menu for easy access in the future.

For more details on how to control settings for negative film scanning, see the section “Negative Scan Settings Window” in the ScanWizard Pro Reference Manual in the Microtek Software CD/DVD.

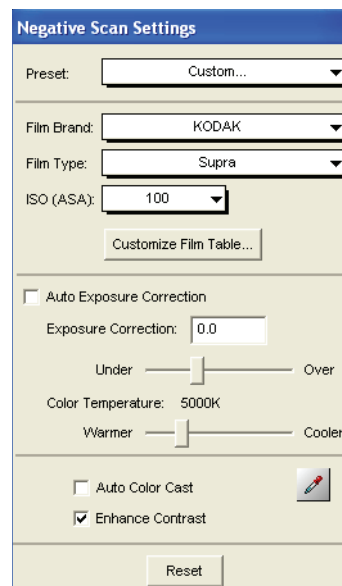
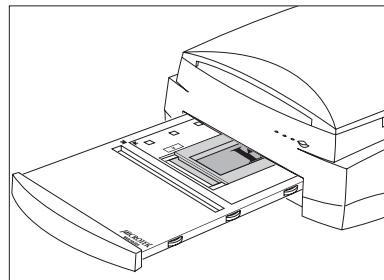

8. Specify your scanning requirements in the *Settings* window.
 - a) Select a desired image type.
 - b) Select a desired resolution.
 - c) Adjust the scan frame settings if necessary.
9. Adjust image quality if necessary, using the Advanced Image Correction (AIC) tools.
10. If the colors in your film are faded and need restoring, check the “Automatic Color Restoration” box in the Settings window.
11. Click the **Scan** (or “Batch”) button in the Preview window to start scanning.
 - If ScanWizard Pro was launched from an application program, the image is then delivered to your application, where the image can be saved, printed, or edited.
 - If ScanWizard Pro was launched in stand-alone mode, you will be prompted to specify the file attributes for the scanned image after the Scan or Batch button is pressed, such as entering the file name, specifying a folder name of your own, etc. When you have completed the settings, press the Done/Save button, and the scanner will automatically scan and save your image based on your settings.

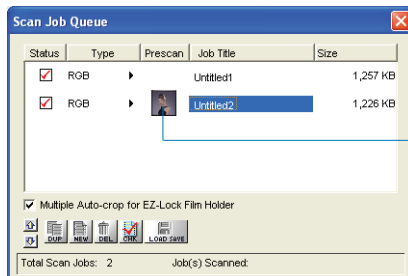
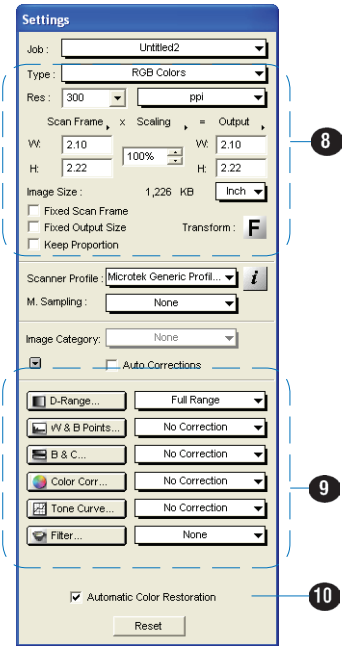
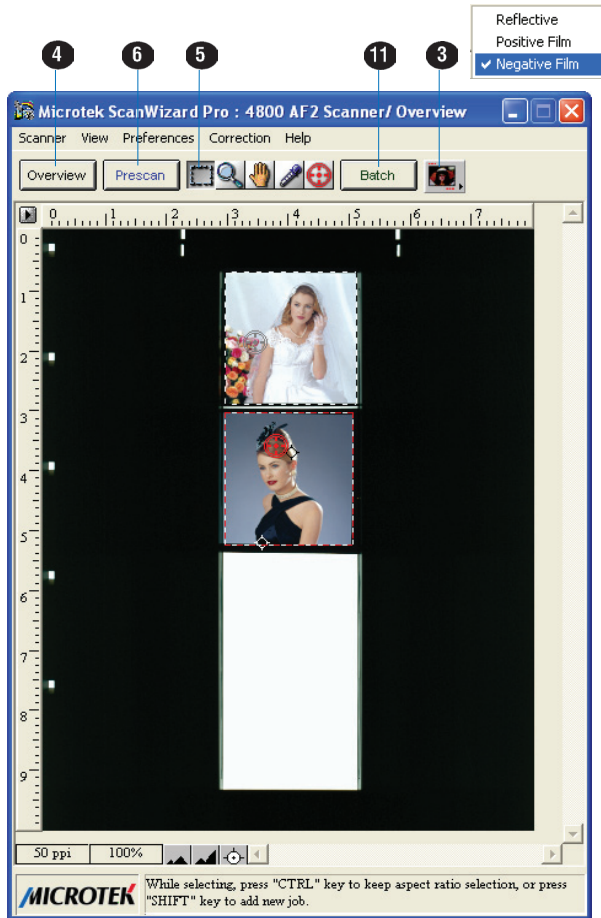

D. Scanning Originals Applied with Auto Focus

1. Follow steps 1 to 3 (or 4) in the previous scanning scenarios to place photos or film, and to launch ScanWizard Pro.

You will see the Auto Focus tool (📷) enabled in the Toolbar if the Auto Focus function is checked in the More Preferences window.

If the Auto Focus tool is disabled (📷) in the Toolbar, go the Preferences menu, and check the “Auto Focus” in the More Preferences window to enable it.

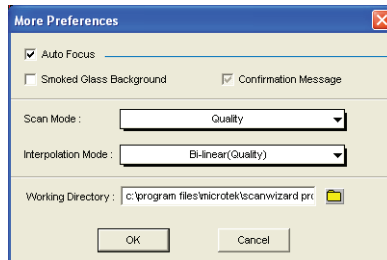
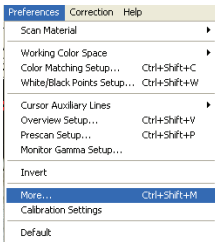

Check the “Auto Focus” option to enable the AF function.

2. Click the **Overview** button to perform a preliminary scan of the image.
3. Select the **Scan Frame** tool from the Toolbar, and choose the area to be scanned by dragging a rectangle around it. You will see a flashing frame (marquee) around the selected area.

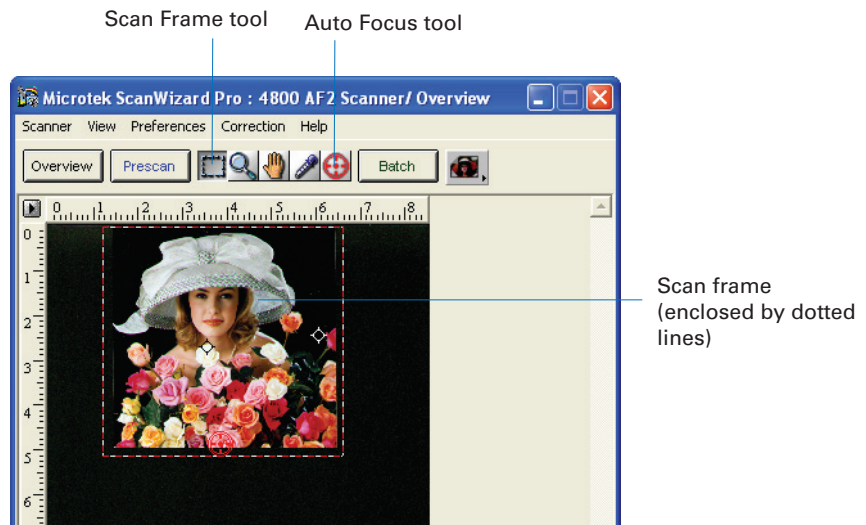

4. Apply the AF function to the image, use either of the ways below:

- Apply the AF function to the whole scan frame.

Click the **Auto Focus** tool in the Toolbar. Move the mouse cursor to the scan frame, then click and drag the AF frame to cover the scan frame. The AF frame will be bordered in red and labeled with the tag “AF”.

In this case, the AF frame and the scan frame are overlapping around the entire image, and display in the Preview window.

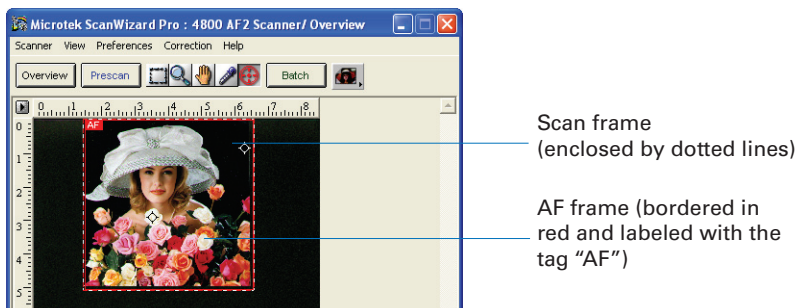

- Apply the AF function to a specific area of the scan frame.

Click the **Auto Focus** tool in the Toolbar. Move the mouse cursor to the scan frame, then click and drag the AF frame to desired size/area in the scan frame to which the AF function will be applied. The AF frame will be bordered in red lines and labeled with the tag “AF”.

Note: The AF frame works only in the area defined by the Scan Frame tool.

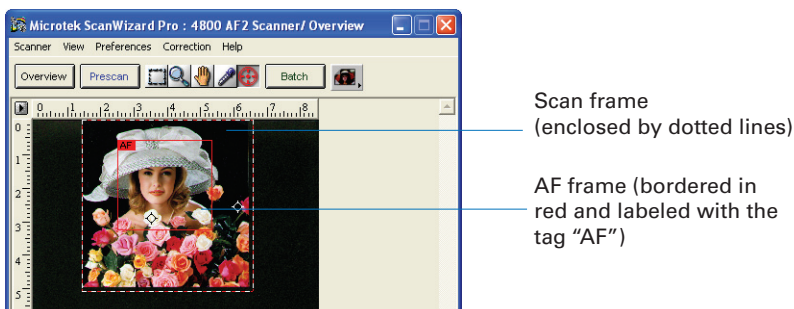

5. Click the **Prescan** button in the Preview window to display a detailed image area selected by the Scan Frame tool.
6. If necessary, follow steps 8 to 10 (or 11) in the previous scanning scenarios to define scan settings for your image.
7. Click the **Scan** (or “Batch”) button in the Preview window to start scanning.

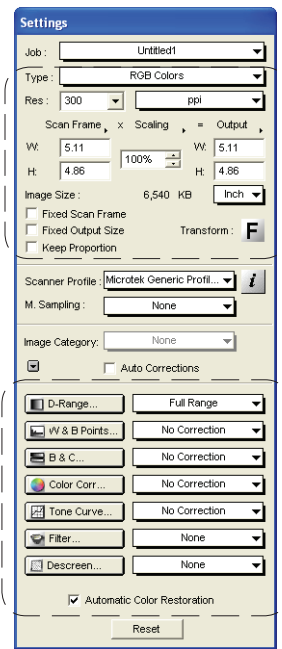
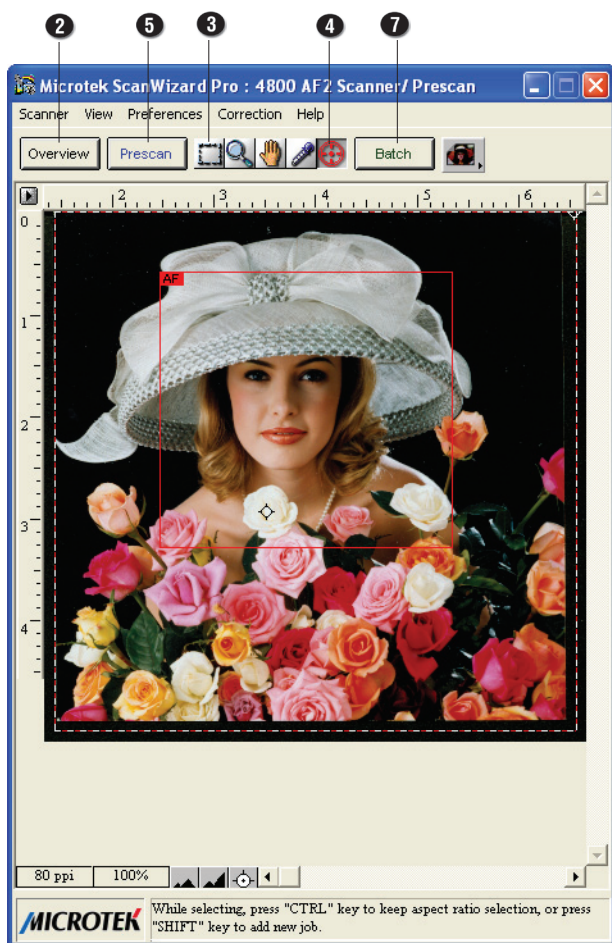

For MAC Users Using ScanPotter

A. Scanning Photos

1. Raise the scanner lid, and place the photo to be scanned face down on the scanner glass bed, towards the front of the scanner. Center the top of the photo along the horizontal ruler on the scanner.
2. Launch ScanPotter either as a stand-alone by clicking on the program icon, or by selecting it from the application folder in your Mac OS X system.
3. Choose **Reflective** from the Scan Source options menu for scanning photos.
4. Specify your scanning requirements in the Scanner Settings column.
 - a) Select the appropriate image type (e.g., RGB Color) in the Color Type as your image output type.
 - Select **Color** to scan the image in color.
 - Select **Grayscale** to scan the image in grayscale.
 - Select **Black & White** to scan the image in black-and-white.
 - b) Select a desired resolution in the Resolution for your output image.
 - c) Select **Automatic Detection** or a desired dimension in the Scan Frame as your preview image size.
5. Click the **Preview** button to perform a preliminary scan of the image in the Preview window.
6. If necessary, resize the scan frame (floating dotted rectangle) around the image by dragging on the square spots on the edge or on the corner of the scan frame to determine the final size of the actual scan.
7. If necessary, specify file settings for your output image files, using the options offered in the File Saving Settings column.
8. If necessary, click the **Image Settings** button to switch to a window in which you can select a preset image effect to the image directly or adjust image quality manually by using the additional image correction tools.
9. Click the **Scan** button to start scanning.

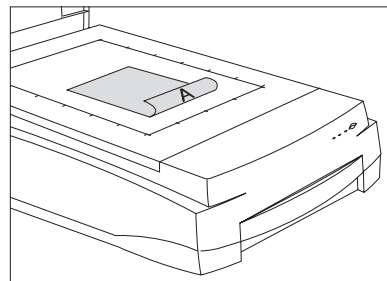

Click the **Scan Settings** button to switch back to the default control panel of ScanPotter

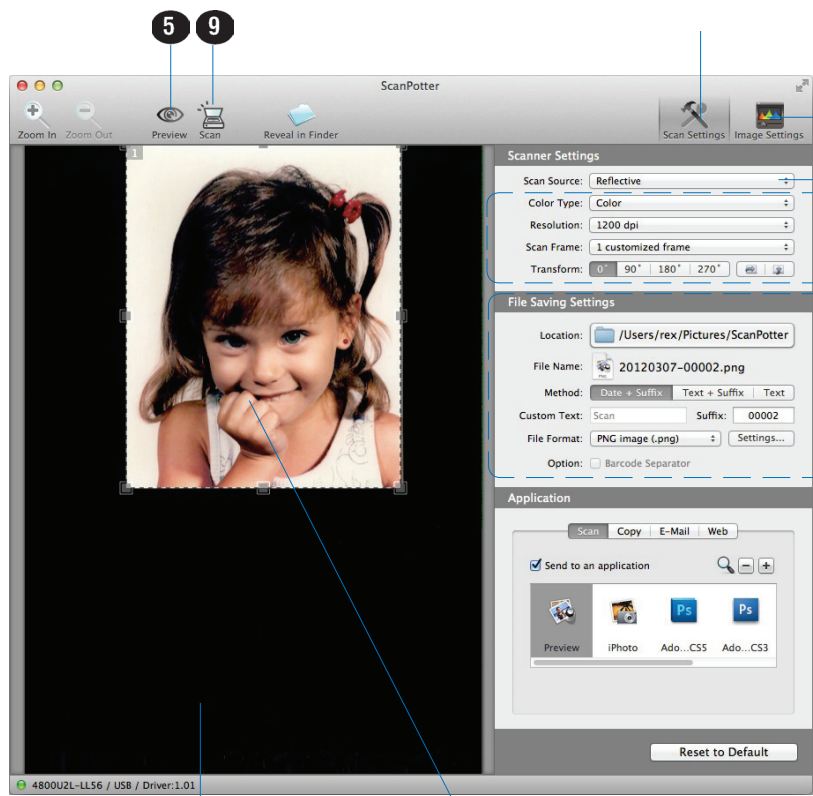

Preview window

6 Scan frame (enclosed by dotted lines)

Click the **Image Settings** button to switch to a window where contains a composite display of nine-image-effects (Filter column) and additional image correction tools (Additional Adjustment column) for your scanned image.

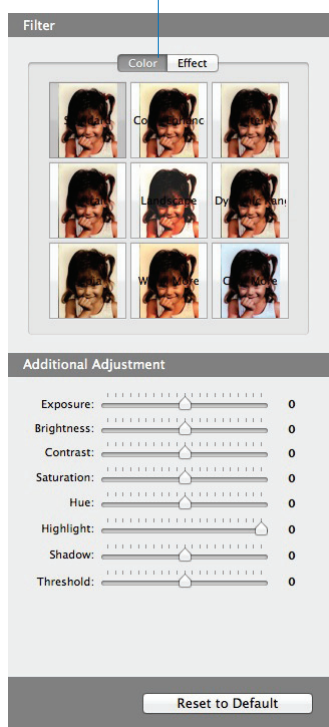

B. Scanning Film

1. Insert the holder with the loaded film into the transparency bay of the scanner. Make sure that nothing is on the scanner glass surface.
2. Launch ScanPotter either as a stand-alone by clicking on the program icon, or by selecting it from the application folder in your Mac OS X system.
3. In the Scan Source drop-down menu, depending on the film type you are using, choose either **Negative Film** for scanning negatives or **Positive Film** for scanning transparencies and slides.
4. Specify your scanning requirements in the Scanner Settings column.
 - a) Select the appropriate image type (e.g., RGB Color) in the Color Type as your image output type.
 - Select **Color** to scan the image in color.
 - Select **Grayscale** to scan the image in grayscale.
 - Select **Black & White** to scan the image in black-and-white.
 - b) Select a desired resolution in the Resolution for your output image.
 - c) Select **Automatic Detection** in the Scan Frame to perform multiple auto-crop preview of the film loaded onto the scanner.
5. Click the **Preview** button to perform a preliminary scan of the image in the Preview window.

You will see multiple scan frames that have been automatically cropped in the Preview window. Multiple scan frames will be numbered sequentially and tagged with the number (e.g., 1, 2) at the top-left corner of each frame indicates that the image has been scanned. Delete the unwanted scan frames by clicking the “X” at the top-right corner of the scan frame if you want to.
6. If necessary, resize the scan frame (floating dotted rectangle) around the image by dragging on the square spots on the edge or on the corner of the scan frame to determine the final size of the actual scan.
7. If necessary, specify file settings for your output image files, using the options offered in the File Saving Settings column.
8. If necessary, click the **Image Settings** button to switch to a window in which you can select a preset image effect to the image directly or adjust image quality manually by using the additional image correction tools.
9. Click the **Scan** button to start scanning.

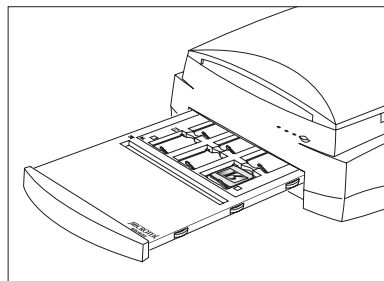

Selected scan frame (enclosed by dotted lines)

Click the **Scan Settings** button to switch back to the default control panel of ScanPotter

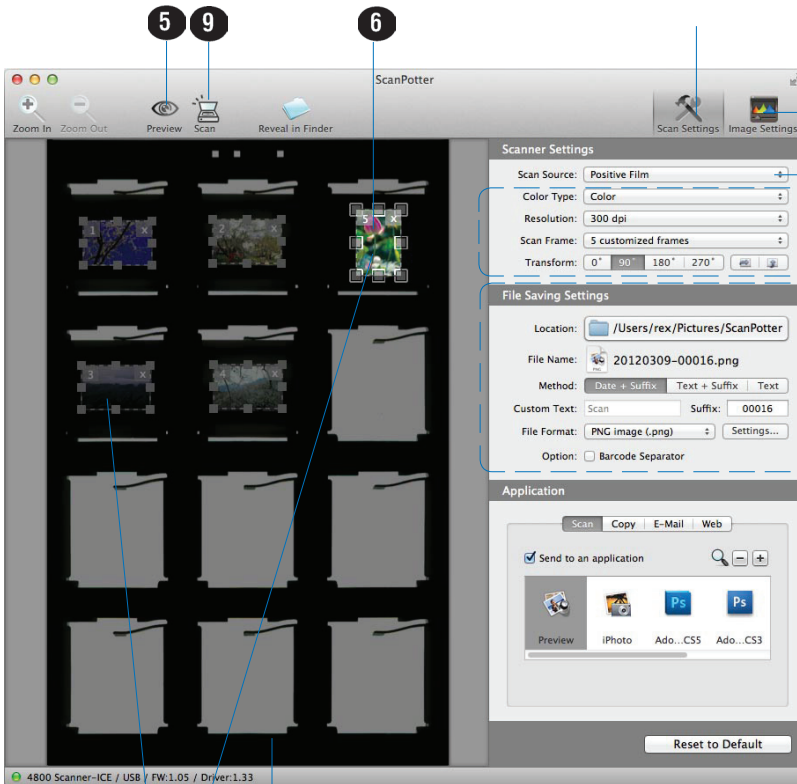

Click the **Image Settings** button to switch to a window where contains a composite display of nine-image-effects (Filter column) and additional image correction tools (Additional Adjustment column) for your scanned image.

Preview window

Multiple scan frames (bordered in dotted lines and tagged with the number (e.g., 1, 2) at the top-left corner of the scan frame)

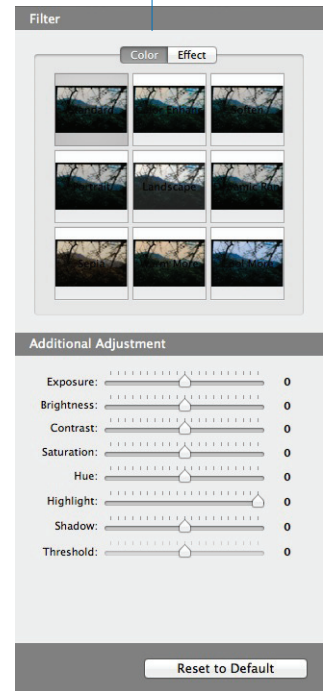

Using the Microtek Scanner ICC Profiler (MSP)

Note: This chapter is only for the PC users who have installed the Microtek's MSP utility, and use the IT8 color targets to generate scanner ICC profiles.

The Microtek Scanner ICC Profiler (MSP) is a scanner calibration and profiling utility program designed exclusively for Microtek scanners. Used together with the color calibration target, the ICC Profiler determines the color attributes of your scanner accurately, then generates an ICC profile tailored exclusively for the scanner that you are using under ScanWizard Pro.

MSP and IT8 Calibration Data Installation

Before installing MSP, ScanWizard Pro needs to be installed on your system. This will ensure that the MSP utility will install and function properly.

To install MSP, take note of the following:

- For PC: Place the **Microtek Software CD/DVD** into a drive, then double click the MSP installer icon. Follow the on-screen instructions to install and you will be prompted to insert the IT8 Calibration Data CD included in your software kit. Insert the **IT8 Calibration Data CD** to ensure that the MSP utility will have the latest color profile targets to reference. Then the MSP installation is complete.

Calibration Target

Two calibration targets (industry-standard IT8 color targets) are included with the SilverFast Ai Studio software kit : a Reflective target (IT8, size 10 x 15-cm) to calibrate the upper scan bed for scanning photos; a Transparency target (IT8, size 6 x 7-cm) to calibrate the lower scan bed for scanning film.

The calibration targets are very delicate and must be handled carefully. Take note of the following:

- Gently remove targets from their respective protective sleeves and avoid touching the target image surface.
- When not in use, keep targets in their sleeves and keep away from light and heat.

Note: To keep the colors in your scanner consistent, you should perform color calibration on a regular basis. Professional photographers, graphic designers or others who require extremely precise color may wish to calibrate the scanner every time it is used.

Positioning the Target

Proper positioning of the target on the scanner is important for successful calibration. Incorrect positioning of the target will result in an unsuccessful calibration.

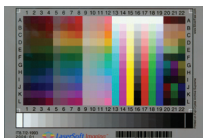

A. Positioning the Reflective Target

Place the reflective target **face down** on the scanner glass bed, making sure that the top end of the target is positioned toward the scanner's front panel, with its edge firmly against the scanner's top ruler.

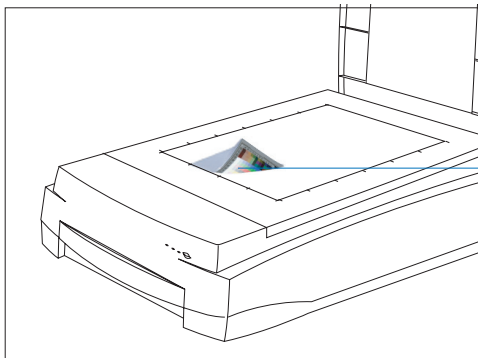

Orientation of the target is critical; make sure that the top end of the target is positioned toward the front of the scanner.



B. Positioning the Transparent Target

1. Place the transparent target face down into the 6 x 22-cm (120) Film Holder; orientation of the target is critical. Make sure that the side of the target (with the barcode) lies towards the front of the scanner .

Refer to the section “C. Using the 6 x 22-cm (120) Film Holder” of this manual to load the film.

2. Place the holder with transparent target into the Main Holder, then put this assembly in the transparency bay of the scanner.

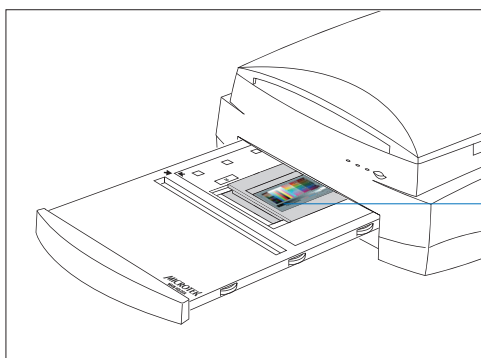

Orientation of the target is critical; make sure that the side of the target (with the barcode) lies towards the front of the scanner — where the barcode is positioned at the bottom-left corner.

Calibration Setup

With the target properly positioned on the scanner, turn on your scanner and let it warm up for about five minutes. Launch the MSP program; the MSP main window appears.

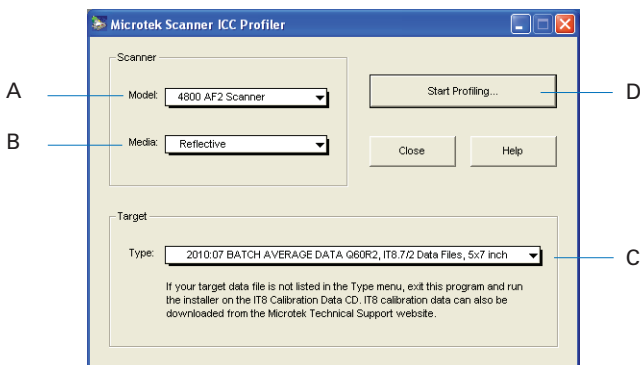

- A. Choose the scanner model that you are calibrating.
- B. Choose the correct target media. If you are calibrating the reflective target, select *Reflective*. Otherwise, select *Positive*.
- C. Select the date code and target type (or reference number) from the drop-down list that matches your target. You can verify this information by looking at the left and right corners of the target's bottom margin.

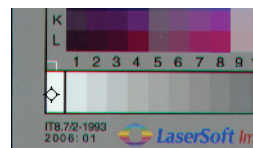

If the desired data file is not present in the drop-down menu, install the IT8 Calibration Data to update the target profiles in your system.

- D. When all the settings are done, click the *Start (or Start Profiling)* button. The calibration window will appear, and an initial preview of the target is performed.

Calibration and Profiling

After the Preview, you are now ready to complete calibration and create a profile for your scanner.

1. Scan the target. To do this, select the entire target by dragging a frame over it, and then click the *Next*>> button.
2. Align the registration marks of the target with your cursor (see inset at bottom of page).
3. Click the Create *Profile* button (or *Finish* button) to create the scanner ICC profile. At the end of the profiling process, a dialog box appears, prompting you to enter a profile name and description.

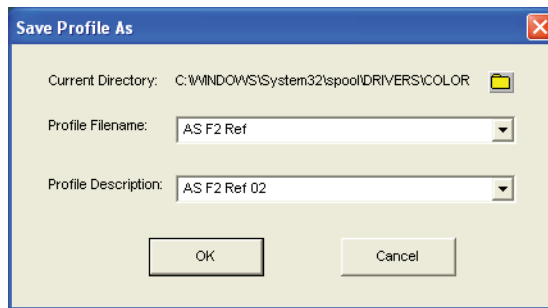

Aligning the Registration Marks

A. Upper-left registration mark

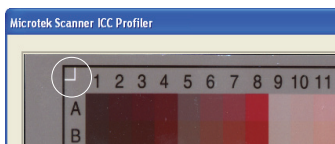

Move the cursor to the target image area; the pointer will change to a horizontally flipped L mark (“┘”). Align the cursor with the small upper-left registration mark.

B. Upper-right registration mark

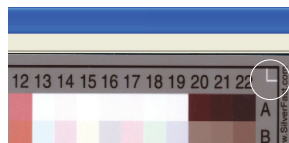

After the upper left mark is aligned, the upper right part of the target image is displayed, and an instruction dialog box prompts you to align the upper right registration mark. Move the cursor to the target image area; the pointer will change to a normal L mark (“L”). Align the cursor with the small upper-right registration mark.

C. Bottom-right registration mark



After the upper right mark is aligned, the lower right part of the target image is displayed, and an instruction dialog box prompts you to align the bottom-right registration mark. Move the cursor to the target image area; the pointer will change to a vertically flipped L mark (“└”). Align the cursor with the small bottom-right registration mark.

Loading a Profile

Once the profile has been produced, follow the steps below to load the profile you just created.

1. Launch ScanWizard Pro.
2. In the Preview window, click the **Scan Material** icon. Select the “Reflective” option for reflective materials; select the “Positive” or “Positive Film” option for transparencies and slides.

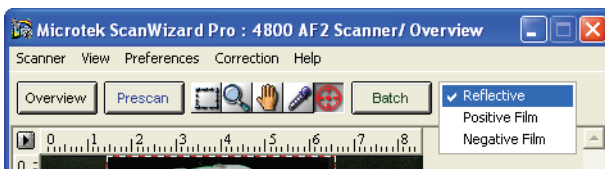

3. From the Settings window, click on the **Scanner Profile/Input Profile** list box, and select the profile you have just created.

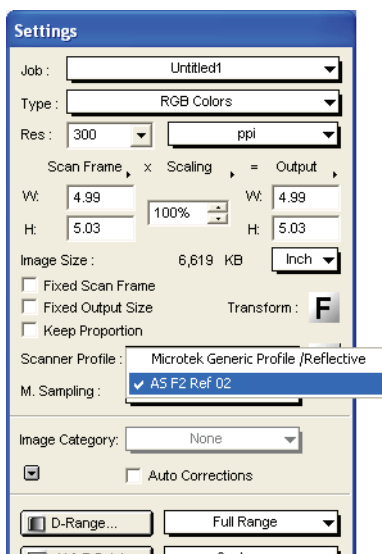

Specifications

Image Sensor	CCD						
Scanning Modes	Color, grayscale, and black-and-white in a single scanning pass True 48-bit color (approx. 281×10^{12} colors) 16-bit grayscale (approx. 65,536 shades of gray)						
Light Source	LED						
Optical Density	4.2 Dmax						
Scanning Area	Reflective: Max. 8.5" x 14" (216 mm x 356 mm) Min. 0.5" x 0.5" (12.7 mm x 12.7 mm) Transparent: Max. 8" x 10" (203 mm x 254 mm) Min. 0.5" x 0.5" (12.7 mm x 12.7 mm)						
Resolution	Optical: 4800 dpi x 9600 dpi						
Interface	Hi-Speed USB (USB 2.0)						
Dimensions (L x W x H)	22.3" x 15.2" x 6.12" (567 mm x 385 mm x 157 mm)						
Weight	26.4 lbs (12 kg)						
Voltage	AC 100V-240V, 50/60 Hz, 2A (Input) DC 24V, 2.5A (Output)						
Power Consumption	60 W Max.						
Power Supply (AC/DC adapter)	<table> <thead> <tr> <th>Voltage</th> <th>MFR</th> <th>Model No.</th> </tr> </thead> <tbody> <tr> <td>AC 100V to 240V</td> <td>Seasonic</td> <td>SSA-0601HE-24</td> </tr> </tbody> </table>	Voltage	MFR	Model No.	AC 100V to 240V	Seasonic	SSA-0601HE-24
Voltage	MFR	Model No.					
AC 100V to 240V	Seasonic	SSA-0601HE-24					
Environment	Operating Temperature: 41° F to 104° F (5° C to 40° C) Relative Humidity: 20% to 85%						

System Requirements

General Requirements

- CD/DVD-ROM drive (for installing software)
- Color display with 24-bit color output capability
- 512 MB RAM or more

PC and compatibles

- Pentium IV PC or higher with Hi-Speed USB (USB 2.0) port
- Microsoft Windows XP / 7 / 8 / 10

Macintosh

- Intel-Based Mac computer with built-in USB port
- Mac OS X 10.6 or later

Important:

Specifications, software bundles, and accessories are subject to change without notice.
Not responsible for typographic errors.

FCC Compliance Statement

This equipment (Model: MRS-4800F2) has been tested and found to comply with the limits for a Class B digital device, pursuant to Part 15 of the FCC rules. These limits are designed to provide reasonable protection against harmful interference in a residential installation. This equipment generates, uses and can radiate radio frequency energy and, if not installed and used in accordance with the instructions, may cause harmful interference to radio communications. However, there is no guarantee that interference will not occur in a particular installation. If this equipment does cause harmful interference to radio or television reception, which can be determined by turning the equipment off and on, the user is encouraged to try to correct the interference by one or more of the following measures:

- Reorient or relocate the receiving antenna.
- Increase the separation between the equipment and receiver.
- Connect the equipment into an outlet on a circuit different from that to which the receiver is connected.
- Consult the dealer or an experienced radio/TV technician for help.

***Note:** A shielded Hi-Speed USB interface cable with ferrite core installed on the scanner connector and must be used with this equipment.*

Caution: Changes or modifications not expressly approved by the manufacturer responsible for compliance could void the user's authority to operate the equipment.

This device complies with Part 15 of the FCC Rules. Operation is subject to the following two conditions: (1) This device may not cause harmful interference, and (2) this device must accept any interference received, including interference that may cause undesired operation.