

Start Here

▼ Installing your Microtek ScanMaker i450

Step 1

Unpack Contents

Unpack your scanner package and check for major components.

1. Scanner with built-in transparency adapter
2. Software CDs/DVDs
3. Power adapter
4. Hi-Speed USB cable
5. Black mat
6. Film holder

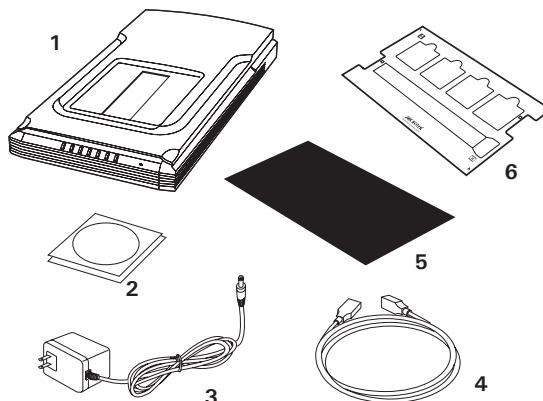

Step 2

Install Software

Important: Do not remove the yellow stickers from your scanner until you are told to do so. You must install software before connecting your scanner.

Always close any open programs and turn off Anti-virus utilities before installing software.

PC:

- A. Place the **Microtek Software CD/DVD** into a drive, and follow the on-screen instructions to install the scanner driver and software.
- B. Restart your computer at the end of all software installation.

NOTE: If the Microtek Software Installer screen does not come up automatically, double-click the following in succession: "My Computer"; the CD/DVD-ROM icon; then cdsetup.exe to start the installer program.

MAC:

- A. Place the **Microtek Software CD/DVD (ScanPotter)** into a drive, and double-click the **ScanPotter** installer icon to install ScanPotter.
- B. Install the remaining software components, then restart your computer at the end of all software installation.

NOTE: After rebooting your Macintosh, the Microtek software will attempt to locate your scanner on the system. Since this is your first install and you have not yet connected the scanner, simply ignore the message that appears and proceed to the next step.

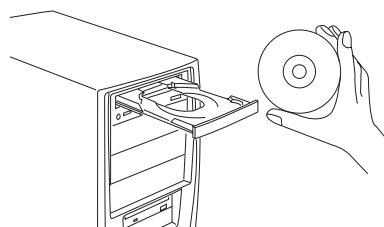

Step 3 Unlock Scanner

- Remove the yellow "Step 3" sticker from your scanner.
- With the scanner power off, tilt the back right corner of the scanner to see the locking switch at the bottom.
- Push the locking switch to the position as indicated in the graphic, with the icon on the lock showing as "Unlocked".

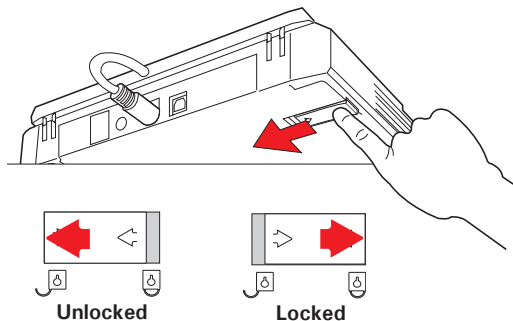

NOTE: To lock the scanner (for shipping and other reasons), tilt the scanner and look for the locking switch on the right corner at the back, then push the locking switch to the "Locked" position. **DO NOT** turn the scanner upside down when attempting to lock the unit.

Step 4 Connect Scanner

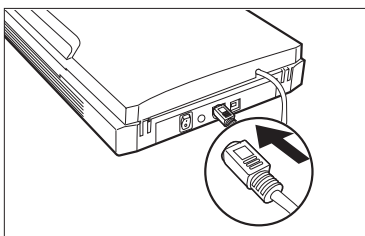

To the scanner lid

Make sure the scanner lid (with built-in transparency adapter) is properly connected to the scanner's 9-pin accessory port. Plug the connector into the port if the scanner lid is not securely connected.

To the power adapter

- Remove the yellow "Step 4" sticker from your scanner.
- Connect the power adapter to the back of the scanner.
- Plug the power adapter into a power source.

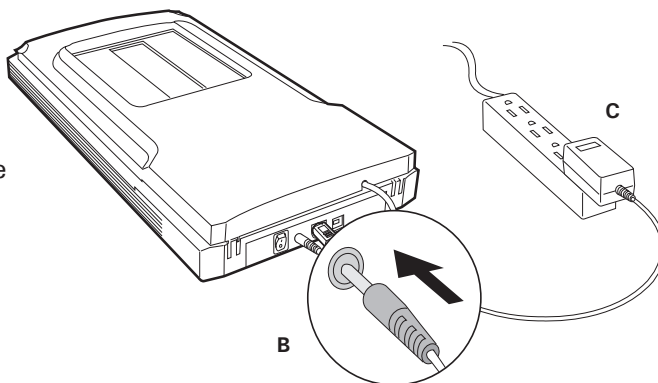

Step 4: Connect Scanner (cont.)

To the Hi-Speed USB cable

- D. Connect one end of the cable to your computer.
- E. Connect the other end of the cable to the scanner.
- F. Turn the power switch at the back panel of your scanner to "On"; the LED lights up at the front panel of the scanner.



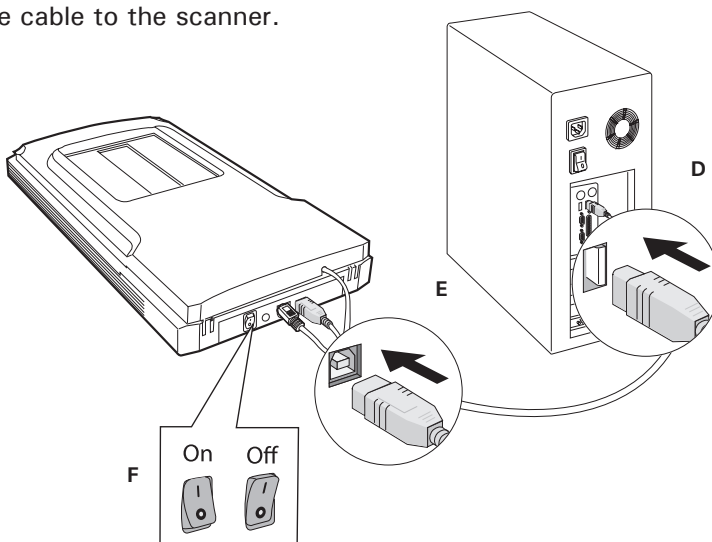



The system will detect your scanner automatically.

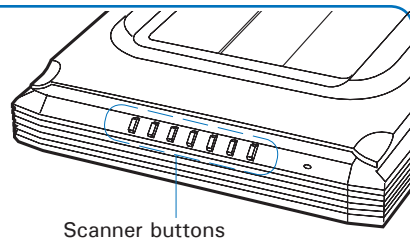

Scanner Buttons

The ScanMaker i450 is equipped with seven scanner buttons, providing quick access to the most frequently used functions. These buttons are **Cancel/Setup**, **Scan**, **Copy**, **E-mail**, **OCR**, **PDF**, and **Custom**.



-  **Cancel/Setup:** Cancels the scanning job when the scanner is scanning. Launches the Microtek Scanner Configuration (MSC) utility when the scanner is not scanning.
-  **Scan:** Captures images that can be saved as files or sent to an image-editing application.
-  **Copy:** Scans the image and sends it to your printer.
-  **E-mail:** Scans the image and delivers it directly to your e-mail editor.
-  **OCR:** Scans a text document, converts, and saves it in text file format.
-  **PDF:** Scans the image and saves it in the Adobe Acrobat PDF format.
-  **Custom:** Customizes this button to perform your preferred function, such as Power Saving, Scan, Fax, or Launch Application.

Position the Scan Material

Position Reflective Materials

To scan reflective materials such as photos and prints, place the photo to be scanned on the scan bed. The top end of the original should be positioned towards the back of the scanner, with the surface to be scanned facing down. Then, place the **Black Mat** on top of the photo.

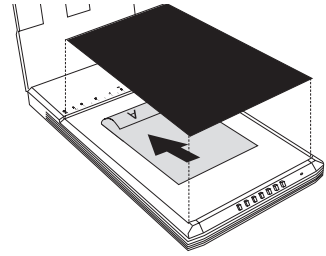

Position Transparencies

To scan transparent film such as 35mm slides and filmstrip, use the film holder.

A. To load film:

1. Load the film inside the holder, with the film's shiny base facing down.

Slide the film along the slots of the holder until the film is fully loaded.

2. Raise the scanner lid, and place the film holder with the film on the scan bed. The holder should be positioned against the top right edge of the scanner bed, with the slot for the film running down the center.

Make sure that the red arrow marks on both the holder and the scanner are pointing to each other when the holder are put together.

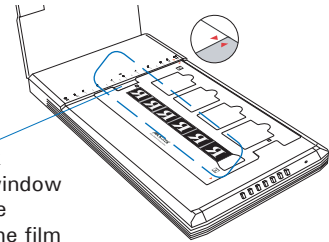
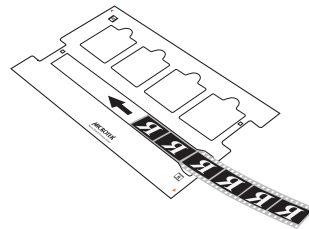

Do not block calibration window
(The U-shape opening at the film slot side)

B. To load slides:

1. Raise the scanner lid, and place the film holder on the scan bed. The holder should be positioned against the top right edge of the bed, with the slot for slides running down the center.

Make sure that the red arrow marks on both the holder and the scanner are pointing to each other when the holder are put together.

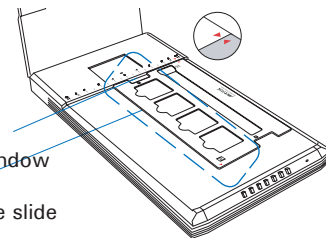

Do not block calibration window
(The U-shape opening at the slide slot side)

2. Place the slide in the film holder, with the slide facing down.

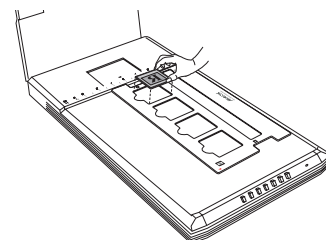

Basic Scanning for PC Users

Scanning Photos

1. Place the photo.

To scan photos, place the photo to be scanned on the scan bed, as detailed in the “Position Reflective Materials” section in this guide.

NOTE: Use of the Black Mat on top of your photo filters out unwanted light during scanning, and ensures the correct functioning of the automatic cropping feature when you do a preview scan.

2. Launch ScanWizard EZ.

To launch ScanWizard EZ as a stand-alone program, double-click the **ScanWizard EZ** icon on your desktop. When ScanWizard EZ is launched for the first time, the control panel of **ScanWizard EZ - EZ Mode** appears automatically.

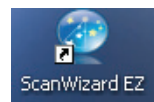

Switches to the Professional Mode
Switches to the Advanced Mode
Activates the Preferences window



Press the Scan button to start scanning

Minimizes ScanWizard EZ

Exits ScanWizard EZ

3. Scan your material.

Click the **Scan** button on the control panel of **EZ Mode** to start scanning.

The ScanWizard EZ will detect the photo on the scanner glass surface first, next automatically calibrate the scanner, crop the image, and finally perform the image scan with factory settings. When done, the scanned image can be saved in a file and delivered to the specified location.

Select preferences if necessary

Before you start scanning, specify image settings related to your output image in the Preferences window according to your preferences.

Auto Settings – Switches on/off Auto-crop and Auto-deskew, and applies ACE (Automatic Color Enhancement) to the image.

Scan Mode – Sets the image resolution and scan quality to match your target application.

Save – Assigns the folder location, a file name, and the file format for the output image. Also, it allows you to specify an application to open the image.

Theme – Changes the appearance of the control panel for the EZ mode.

NOTE: For details about how to use the ScanWizard EZ's Advanced Mode and Professional Mode, refer to the ScanMaker i450 Supplement.

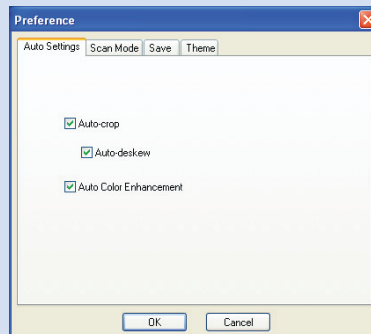

Scanning Film

- Place the film.
To scan film, use the film holder, as detailed in the "Position Transparencies" section in this guide.
- Launch ScanWizard EZ.
Follow the step 2 in "Scanning Photos" on the previous page to launch ScanWizard EZ.
- Switch to ScanWizard EZ - Professional Mode.
Click the **Professional Mode** button on the control panel of the EZ Mode to switch to the Professional Mode.
- In the Preview window of the Professional Mode, click the **Scan Material** button to choose **Negative Film** for negatives; choose **Positive Film** for transparencies and slides, depending on the film type you are using.
- Select the **Scan Frame** tool, and choose the area to be scanned by sizing the marquee around the targeted area.
- Click the **Overview** button to perform a preliminary scan of the film loaded onto the scanner.
- Specify your scanning requirements in the Settings window. Choose the desired image type and resolution, and adjust the scan frame settings if necessary.
- Adjust image quality if necessary, using the Advanced Image Correction tools.
- Click the **Scan to** button in the Preview window to scan the film.

Press to switch to ScanWizard EZ - EZ Mode
Press to switch to ScanWizard EZ - Advanced Mode

Settings window

Scan Job Queue window

Click NEW to create more scan frames

Status	Type	Job Title	Size
✓	RGB	Untitled1	364 KB
✓	RGB	Untitled2	367 KB
✓	RGB	Untitled3	364 KB

Basic Scanning for Mac Users

1. Place the scan material.
 - To scan photos, place the photo to be scanned on the scan bed, as detailed in the “Position Reflective Materials” section in this guide.
 - To scan film, use the film holder, as detailed in the “Position Transparencies” section in this guide.
2. Launch ScanPotter as a stand-alone by clicking on the program icon, or by selecting it from the application folder in your Mac OS X system.
3. In the Scan Source options menu, depending on the scan material you are using, choose either **Reflective** for photos, **Negative Film** for negatives, or **Positive Film** for transparencies and slides.
4. Specify your scanning requirements in the Scanner Settings column.
 - a) Select the appropriate image type (e.g., RGB Color) in the Color Type as your image output type.
 - Select **Color** to scan the image in color.
 - Select **Grayscale** to scan the image in grayscale.
 - Select **Black & White** to scan the image in black-and-white.
 - b) Select a desired resolution in the Resolution for your image output resolution.
 - c) Select **Automatic Detection** or a desired dimension in the Scan Frame as your preview image size.
5. Click the **Preview** button to perform a preliminary scan of the image in the Preview window.
6. If necessary, resize the scan frame (floating dotted rectangle) around the image by dragging on the square spots on the edge or on the corner of the scan frame to determine the final size of the actual scan.
7. If necessary, specify file settings for your output image files, using the options offered in the File Saving Settings column.
8. If necessary, click the **Image Settings** button to switch to a window in which you can select a preset image effect to the image directly or adjust image quality manually by using the additional image correction tools.
9. Click the **Scan** button to start scanning.

NOTE: For details on scanning photos and film, see the ScanMaker i450 Supplement in the Microtek Software CD/DVD.

Scan frame (enclosed by dotted lines)

Click the Scan Settings button to switch back to the default control panel of ScanPotter

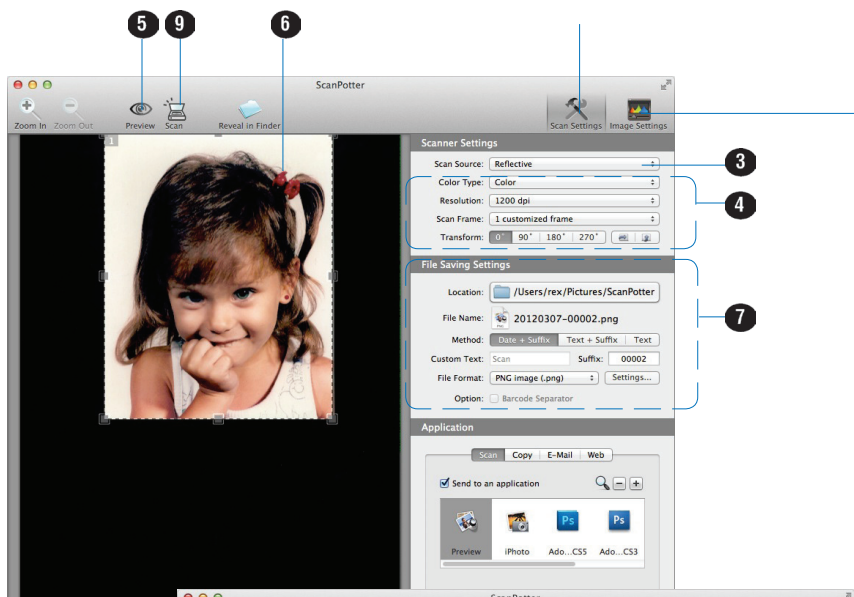

Click the Image Settings button to switch to a window where contains a composite display of nine-image-effects (Filter column) and additional image correction tools (Additional Adjustment column) for your scanned image.

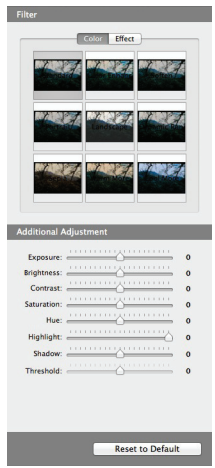

Preview window when scanning photos

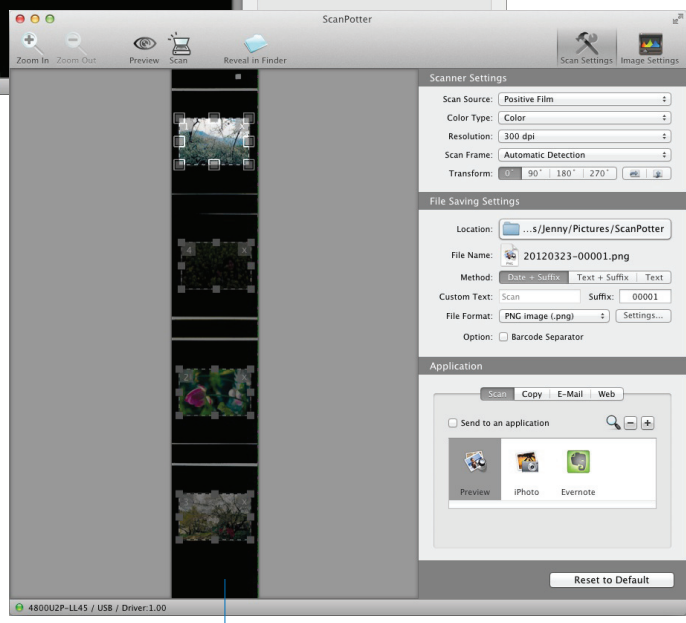

Preview window when scanning slides

Problems?

The LED on the button panel indicates the status of the scanner.



On - Ready to scan



Flashing - Scanning



Off - Scanner is off

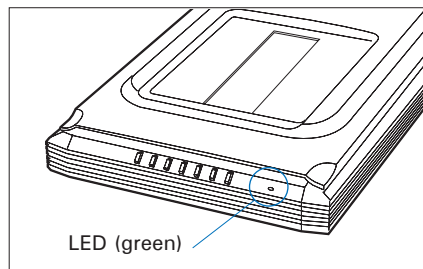

If you encounter any problems, check the section below and follow the suggested solution if your problem is listed. You may also want to go over installation steps 1 to 4 of this “Start Here” document to make sure that you have followed all procedures properly.

1. No light comes on when the scanner is turned on.

Make sure your scanner is connected to your computer and plugged into a power source.

2. Add/Remove Hardware Wizard appears on your screen.

Click the “Cancel” button and close the control panel. Disconnect the USB cable from the back of your computer, and refer to the installation instructions in this guide.

3. When trying to scan, an error message appears on your screen that reads, “Can’t Find Scanners”. Make sure your scanner is unlocked (see Step 3).

Make sure your scanner is connected to your computer and plugged in to a power source (see Step 4).

Uninstall and reinstall the ScanWizard EZ or ScanPotter software.

4. After clicking scan, a blank screen appears.

Make sure your scanner is unlocked (see Step 3).

Uninstall and reinstall the ScanWizard EZ or ScanPotter software.

5. Having trouble scanning negatives or slides?

Make sure the scanner lid (with built-in transparency adapter) is properly installed, with its connector securely connected to the scanner’s 9-pin accessory port.

Make sure you place the film holder with the loaded film properly on the scan bed. Do not block the calibration area (as indicated in the “Position Transparencies” section).

From the **ScanWizard EZ - Professional Mode**, go to the Preview window, then click the **Scan Material** button to select either the **Positive Film** or **Negative Film** option.

From the **ScanPotter**, go to the Scanner Settings column, then click the **Scan Source** drop-down menu to select either the **Positive Film** or **Negative Film** option.

Uninstall and reinstall the ScanWizard EZ or ScanPotter software.

Do You Need Assistance?

Manuals

If you have additional questions and need further instruction or information, we provide electronic manuals for:

1. Using your ScanMaker i450 (Supplementary information)
2. Using the ScanWizard EZ or ScanPotter scanning software
3. Using the bundled third-party software

To access the electronic manuals: Insert the scanner's software CD/DVD into your computer's CD/DVD-ROM drive. Next, locate and click the "Manuals" option when the software installer window appears on your screen. Finally, select and click the title of the manual you wish to view.

Missing Items

If your package is missing items, please call the Microtek Customer Service Department.

Drivers & Software Upgrades

After you finish the installation of software, if you found that the installed drivers and software cannot run your product or your computer system properly later, please go to the Microtek Download Service site at www7.microtek.com.tw/service.php to download and install any updates you may require.

For additional information about Microtek products, please visit our website at www.microtek.com.

Power Adapter

Use only power supplies (AC/DC adapters) listed below:

Voltage	Manufacturer	Model No.
100V to 240V	WUXI HARD	HDAD-120015-3C (U.S.)
100V to 240V	WUXI HARD	HDAD-120015-3B (Europe)
100V to 240V	WUXI HARD	HDAD-120015-3D (AUS)
100V to 240V	WUXI HARD	HDAD-120015-3E (UK)
100V to 240V	MEAN WELL	GS18U12 (TWN)

NOTE: Please make sure that the electrical outlet to where the scanner will be connected is nearby and readily accessible.

Copyright © 2017 Microtek. Microtek, ScanMaker, ArtixScan, ScanWizard and ColoRescue are trademarks or registered trademarks of Microtek International, Inc. All other trademarks or registered trademarks are the property of their respective holders. Specifications, software and hardware bundles are subject to change without notice. Delivery of technical support services subject to change without notice. Not responsible for typographical errors.

